

# TRADING GRANDFATHERED AIR— A NEW, SIMPLER APPROACH

*Brian H. Potts\**

## INTRODUCTION

This Article addresses one of the most hotly contested issues in environmental law today—the New Source Review (“NSR”) modification requirement—and proposes a simpler and superior approach. Over the last few years there have been four federal appellate court decisions,<sup>1</sup> five district court decisions,<sup>2</sup> six EPA rulemakings,<sup>3</sup> and copious Congressional bills<sup>4</sup> dealing with, or directly influencing, various aspects of this require-

---

\* Energy and Environmental Law Attorney, Michael Best & Friedrich; LL.M., University of California, Berkeley School of Law (Boalt Hall), 2006; J.D., Vermont Law School, 2004; B.S., Centre College, 2001. I would like to thank Professors Daniel Farber and Steven Weissman for their legal guidance and Professor Alex Farrell of the University of California, Berkeley’s Energy and Resources Group for his helpful comments on the spatial and temporal effects of NO<sub>x</sub> and SO<sub>2</sub>.

<sup>1</sup> *United States v. Cinergy Corp.*, 485 F.3d 705 (7th Cir., 2006) (upholding EPA’s annual emissions increase test for NSR); *New York v. EPA*, 443 F.3d 880, 883 (D.C. Cir. 2006) (invalidating Equipment Replacement Provision of the Routine Maintenance, Repair, and Replacement Exclusion, 68 Fed. Reg. 61,248 (Oct. 27, 2003) (final rule)); *United States v. Duke Energy Corp.*, 411 F.3d 539, 550 (4th Cir. 2005) (invalidating the hourly/yearly distinction in NSR and the New Source Performance Standards (“NSPS”)); *New York v. EPA*, 413 F.3d 3, 10 (D.C. Cir. 2005) (upholding the majority of EPA’s 2002 emissions increase rule).

<sup>2</sup> *United States v. Cinergy Corp.*, 384 F.Supp.2d 1272 (S.D. Ind. 2005) (upholding EPA’s annual emissions increase test for NSR); *United States v. Ala. Power Co.*, 372 F.Supp.2d 1283 (N.D. Ala. 2005) (interpreting the routine maintenance provision and the emissions increase rule); *United States v. Ohio Edison Co.*, 276 F.Supp.2d 829 (S.D. Ohio 2003) (finding that EPA should look at the industry, as a whole, rather than to the specific source when determining what constitutes routine maintenance); *United States v. Duke Energy Corp.*, 278 F.Supp.2d 619, 647–49 (M.D.N.C. 2003) (applying the “actual-to-actual” emissions increase test and looking to what is routine at the source); *United States v. S. Ind. Gas & Elec. Co.*, 245 F.Supp.2d 994 (S.D. Ind. 2003) (finding that EPA’s interpretation of the routine maintenance provision is reasonable).

<sup>3</sup> Prevention of Significant Deterioration (PSD) and Nonattainment New Source Review (NSR): Debottlenecking, Aggregation, and Project Netting, 71 Fed. Reg. 54,235 (Sept. 16, 2006); Prevention of Significant Deterioration, Nonattainment New Source Review, and New Source Performance Standards: Emissions Test for Electric Generating Units, 70 Fed. Reg. 61,081 (Oct. 20, 2005) (proposed rule); Standards of Performance for New and Existing Stationary Sources: Electric Utility Steam Generating Units, 70 Fed. Reg. 28,606 (May 18, 2005) (final rule) (Clean Air Mercury Rule (“CAMR”)); Rule to Reduce Interstate Transport of Fine Particulate Matter and Ozone (Clean Air Interstate Rule), Revisions to Acid Rain Program, Revisions to the NO<sub>x</sub> SIP Call, 70 Fed. Reg. 25,162 (May 12, 2005); Equipment Replacement Provision of the Routine Maintenance, Repair and Replacement Exclusion, 68 Fed. Reg. 61,248 (Oct. 27, 2003) (final rule); Prevention of Significant Deterioration (PSD) and Nonattainment New Source Review (NSR): Baseline Emissions Determination, Actual-to-Future-Actual Methodology, Plantwide Applicability Limitations, Clean Units, Pollution Control Projects, 67 Fed. Reg. 80,186 (Dec. 31, 2002) (final rule).

<sup>4</sup> See JAMES E. MCCARTHY, CLEAN AIR ACT ISSUES IN THE 108TH CONGRESS 6–8

ment.<sup>5</sup> Underlying all of this action lays one contentious issue: How and to what extent should this nation force older, originally grandfathered power plants to upgrade their pollution control equipment? This issue is so divisive because power plant pollution is the greatest single source of air pollution in this country, yet low-cost power is critical to this nation's economy. Although abating this pollution would lead to higher nationwide energy costs, according to a recent Congressional report, power plant pollution kills approximately 30,000 people annually in this country—about the same number as the annual deaths from drunk driving and homicides combined.<sup>6</sup> Yet, because of various grandfathering provisions, only about one-quarter of all power plants have completely updated pollution control equipment and over sixty percent are wholly exempt from many Clean Air Act (“CAA”) requirements.<sup>7</sup> This Article addresses this grandfathering conundrum in detail, examining the law, technology, and prominent scholarly proposals, and provides an innovative and feasible new solution: the Most Effective Best Available Control Technology (“MEBACT”) approach.<sup>8</sup>

Economists use the term vintage-differentiated regulation to describe what others often call grandfathering.<sup>9</sup> Stated simply, vintage-differentiated legislation mandates different standards for regulated entities based primarily on each entity's date of entry into the market, where earlier entries face less stringent regulation.<sup>10</sup> Several of the CAA's provisions, principally the New Source Performance Standards (“NSPS”) and NSR provisions, contain typical vintage-differentiated language. New sources meet the toughest standards, while existing sources must meet progressively less stringent emissions limitations based on when each facility was constructed or modified. For example, facilities constructed or modified after 1990 must meet more stringent standards than facilities constructed or modified between 1978 and 1990, while facilities constructed or modified be-

---

(Cong. Research Serv., CRS Issue Brief for Congress Order Code IB10107, Nov. 30, 2004), available at <http://www.ncseonline.org/NLE/CRSreports/04nov/IB10107.pdf> (outlining all of the major Congressional proposals).

<sup>5</sup> For further analysis of various portions of the rule and a discussion of the emissions increase portion of the modification rule, see Brian H. Potts, *The U.S. Supreme Court's New Dukedom, the Hour and Year, or a Proposal Quite Near*, 33 *ECOLOGY L.Q.* (forthcoming 2006). See also Robert A. Greco, P.E., *When Is Routine Maintenance Really Routine? A Proposed Modification to the EPA's New Source Review Program*, 88 *MARQ. L. REV.* 391, 391 (2004) (discussing the routine maintenance portion of the modification rule).

<sup>6</sup> *Hearing Before the Comm. on Environment and Public Works, Health Impacts of PM<sub>2.5</sub> Associated with Power Plant Emissions*, 107th Cong. 3 (2002).

<sup>7</sup> For a more detailed discussion of these statistics, see *infra* Parts II, VI.

<sup>8</sup> The MEBACT approach aims to limit the social welfare losses associated with the CAA's current trading regimes by forcing certain grandfathered facilities over time to install the most effective pollution control technology. See *infra* Part V for a more detailed discussion.

<sup>9</sup> ROBERT N. STAVINS, RES. FOR THE FUTURE, *THE EFFECTS OF VINTAGE-DIFFERENTIATED ENVIRONMENTAL REGULATION 1* (2005), available at <http://www.rff.org/Documents/RFF-DP-05-12.pdf>.

<sup>10</sup> *Id.*

tween 1971 and 1978 must meet significantly less stringent regulations than either group.<sup>11</sup> Pre-1971 facilities that have not been significantly modified must meet the least stringent emissions limitations; in fact, the majority of their emissions are not even federally regulated.<sup>12</sup>

Grandfathering provisions were not new when Congress passed the CAA in 1970; indeed, some argue that they were first introduced in the United States between 1890 and 1910, to prevent non-whites from voting.<sup>13</sup> Today, grandfathering is ubiquitous across many sectors. Occupational licensing regulations, construction codes, zoning restrictions, consumer product safety laws, and even tax reforms all contain grandfathering provisions.<sup>14</sup> Of course, the most recognized grandfathering provisions are found in automobile regulations, whereby new automobiles must meet strict technological emission limitations while older automobiles are exempt.<sup>15</sup>

Scholars and legislators forward many reasons for grandfathering, but there are three overlying tenets among them: (1) grandfathering is cost-effective; (2) it is fair; and (3) it is politically advantageous.<sup>16</sup> The rationales for these three tenets are fairly obvious. In the environmental realm, grandfathering is considered cost-effective because the cost to retrofit sources often exceeds the cost to build a new facility.<sup>17</sup> It is considered fair because existing facilities cannot be expected to forecast "changing social norms, scientific understanding of pollution, and governmental regulations."<sup>18</sup> Finally, grandfathering is considered politically advantageous because potential future sources often do not have as much political capital as existing sources.<sup>19</sup>

While there is general agreement as to the legislatures' rationales for implementing grandfathering legislation, there has also been long-standing agreement among economists that these age-discriminating regulations "retard turnover of the capital stock, drive up the cost of environmental

---

<sup>11</sup> See *infra* Part I.A.

<sup>12</sup> See 40 C.F.R. §§ 60.42–44 (2006).

<sup>13</sup> See Heidi Gorovitz Robertson, *If Your Grandfather Could Pollute, So Can You: Environmental "Grandfather Clauses" and Their Role in Environmental Inequity*, 45 CATH. U. L. REV. 131, 131 (1995) (citing Karen McGill Arrington, *The Struggle to Gain the Right to Vote, in VOTING RIGHTS IN AMERICA: CONTINUING THE QUEST FOR FULL PARTICIPATION* 30 (Karen McGill Arrington & William L. Taylor eds., 1992)).

<sup>14</sup> Arik Levinson, *Grandfather Regulations, New Source Bias, and State Air Toxics Regulations*, 28 ECOLOGICAL ECON. 299, 299 (1999).

<sup>15</sup> See *id.* at 299 n.1 ("These technological requirements include the corporate average fuel economy (CAFE) standards, as well as emissions limits that are met by installing catalytic converters. In both cases, the increasingly stringent standards apply only to new automobiles; used cars are exempt"); see also H. K. Gruenspecht, *Differentiated Regulations: The Case of Auto Emissions Standards*, 72 AMER. ECON. REV. 328, 328–31 (1982).

<sup>16</sup> See, e.g., STAVINS, *supra* note 9, at 1; Levinson, *supra* note 14, at 300.

<sup>17</sup> Levinson, *supra* note 14, at 300.

<sup>18</sup> *Id.*

<sup>19</sup> STAVINS, *supra* note 9, at 1.

protection, and may retard pollution abatement.”<sup>20</sup> The retort to this blatant conflict between economists and legislators is rudimentary: the powerful and large political constituencies who lobby legislators to protect the profitability and capital investments of their existing infrastructure far outweigh in number and influence those lobbying for future, currently uncapitalized projects. Economically speaking, grandfathering is not the most cost-effective alternative, but in practice, grandfathering is often a necessary evil. What is important to note from all this is that grandfathering regulations do have inherent economic problems—for example, they slow new investment and are not always cost-effective.<sup>21</sup>

The critical notion presented in this Article is that the current structure of the CAA and its regulations exacerbate these grandfathering problems. However, the trouble with typical age-discriminating regulations only partially explains the inherent flaws in the CAA’s grandfathering provisions. The principle dilemma, what some have termed the “unintended disincentive in the Clean Air Act,”<sup>22</sup> is that when existing sources are modified, they must comply with the same extremely stringent standards as new sources.<sup>23</sup> Recent empirical economic studies have shown that this “unintended disincentive” in the CAA has retarded modification rates and done little to hasten old-plant closings, which was a central purpose of these culprit provisions when enacted.<sup>24</sup> This Article argues for the removal of these retarding CAA provisions (namely NSR and the NSPS) for existing fossil-fuel electric generating units and proposes a new legislative approach for dealing with these sources. More specifically, given the current emissions trading regimes,<sup>25</sup> Congress should enact a new section in the CAA that addresses existing fossil-fuel electric generating units that would: (1) exempt all existing fossil-fuel generating units from NSR and the NSPS emissions limitations; (2) introduce a new form of technology-forcing timeline for all existing units; and (3) introduce a new type of technology-forcing standard called the MEBACT standard.

Part I of this Article will outline the relevant portions of the CAA, including a thorough discussion of NSR, the NSPS, their corresponding technology standards, and the current emissions trading regimes. Part II

---

<sup>20</sup> *Id.* at 15.

<sup>21</sup> *Id.* at 5. There have, however, been empirical studies disputing the capital investment disincentive issue. See, e.g., Levinson, *supra* note 14, at 299 (“In general, there seem to be no statistically significant differences in capital vintage or investment between plants in states that grandfather new sources of pollution, plants in states that have no air toxics regulations, and plants in states that regulate both new and existing sources.”).

<sup>22</sup> John A. List et al., *The Unintended Disincentive in the Clean Air Act*, 4 *ADVANCES IN ECON. ANALYSIS & POL’Y* 1 (2004), available at <http://www.bepress.com/cgi/viewcontent.cgi?article=1204&context=bejeap>.

<sup>23</sup> See 42 U.S.C. §§ 7479(3), 7501(3) (2006) (providing that certain new or modified sources must meet stringent technology standards).

<sup>24</sup> List et al., *supra* note 22, at 1.

<sup>25</sup> There are currently a number of bills in Congress attempting to introduce market-based permit regimes for various pollutants. MCCARTHY, *supra* note 4, at 6–8.

will then discuss the environmental control technologies and costs associated with electric power generation, focusing primarily on coal-burning power plants. After examining the ramifications and constraints associated with these control technologies, the discussion becomes more theoretical in Part III, first examining the economics of trading and the problems associated with the quantity-based trading systems, and then turning to NSR's negative interaction with these trading regimes through a numerical example. Following this analysis, Part IV examines the three foremost proposals for maximizing welfare without the NSR and NSPS modification rules, two advocating emissions trading reform and one arguing for a pure command-and-control approach. Then Part V introduces the MEBACT approach, including a textual CAA amendment, and illustrates that the approach's potential benefits far outweigh any likely shortcomings. Finally, Part VI will provide statistics on the number and severity of the grandfathered power plants in this nation and will conclude with cost estimates for a universal control technology upgrade.

#### I. AN INTRODUCTION TO THE CAA AND ITS GRANDFATHERING PROVISIONS

The Clean Air Act controls both site-specific air pollution and ambient outdoor air quality through various complex and often-interrelated provisions. Like most federal environmental statutes, the CAA generally creates federal standards and allows states to pass legislation or regulations to meet these standards.<sup>26</sup> A state's primary involvement is during the creation of a State Implementation Plan ("SIP").<sup>27</sup> In order to meet EPA-mandated outdoor ambient air levels,<sup>28</sup> states can choose to either promulgate a SIP, which is subject to EPA approval, or allow EPA to regulate pursuant to a federal implementation plan ("FIP").<sup>29</sup> The EPA-promulgated ambient air levels are known as National Ambient Air Quality Standards ("NAAQS").<sup>30</sup> They set outdoor-air concentration ceilings for six criteria pollutants<sup>31</sup> averaged over specific time periods (e.g., an eight-hour period).<sup>32</sup>

Although SIPs and FIPs regulate many industrial sectors, this Article is only concerned with stationary sources of air pollution, primarily fos-

---

<sup>26</sup> See, e.g., 42 U.S.C. § 7410 (2006) (allowing states to create state implementation plans to meet National Ambient Air Quality Standards ("NAAQS")).

<sup>27</sup> *Id.*

<sup>28</sup> 42 U.S.C. §§ 7408–09 (2006); TOM TIETENBERG, ENVIRONMENTAL ECONOMICS AND POLICY 265 (3d ed. 2001).

<sup>29</sup> 42 U.S.C. § 7410.

<sup>30</sup> *Id.* "Compliance with NAAQS are determined primarily from monitoring data from sites within the area. If one monitoring site within an area is in noncompliance with NAAQS, the entire area is noncompliant for that pollutant." ARNOLD W. REITZE, JR., STATIONARY SOURCE AIR POLLUTION LAW 33 (2005).

<sup>31</sup> The six current criteria pollutants are sulfur dioxide (SO<sub>2</sub>), nitrous oxides (NO<sub>x</sub>), ozone (O<sub>3</sub>), particulate matter (PM<sub>2.5</sub>), carbon monoxide (CO), and lead (Pb).

<sup>32</sup> See 42 U.S.C. §§ 7408–09.

oil-fueled power plants. The chief pollution control technique for these sources stems from pre-construction and operating permit requirements, and market-based allowance systems (for SO<sub>2</sub> and NO<sub>x</sub>). In order to build or modify a facility, the CAA requires a major source to obtain a pre-construction permit, and then to obtain an operating permit.<sup>33</sup> These permits mandate strict emissions limitations and work-practice procedures.<sup>34</sup> The preconstruction permit acts as the “government’s lever,” ensuring that it is extensively involved in the project’s design and construction phases.<sup>35</sup> The operating permit, established under Title V of the CAA, ensures that the facility will meet its emissions standards and work-practice procedures during operation and allows the state or federal agency to tighten the standards as needed upon permit renewal (every five years).<sup>36</sup> For unmodified grandfathered sources, EPA does not impose specific requirements; rather, states generally determine emissions limitations on their own as long as the state’s SIP is adequate and the state meets other CAA requirements.<sup>37</sup>

#### A. New Source Performance Standards

When determining emissions limitations for a new or modified source’s operating permit, the agency first consults EPA’s NSPS regulations, which serve as the baseline.<sup>38</sup> The NSPS regulations impose uniform emissions limitations nationwide for various source categories.<sup>39</sup> However, the NSPS regulations do not apply to facilities that were in existence when the regulations were finalized.<sup>40</sup> The NSPS standards are supposed to impose emission limitations on new and modified sources based on the best system of emissions reductions that has been adequately demonstrated.<sup>41</sup> When promulgating an NSPS emission limitation, EPA can consider costs, energy requirements, and non-air-quality health and environmental impacts in determining the appropriate control technology.<sup>42</sup> This level of control is typically referred to as the best demonstrated technology (“BDT”).<sup>43</sup> Generally speaking, the NSPS emissions limitations are some-

---

<sup>33</sup> See 42 U.S.C. §§ 7475, 7503 (2006).

<sup>34</sup> See *id.*

<sup>35</sup> See REITZE, *supra* note 30, at 161.

<sup>36</sup> 42 U.S.C. § 7661a(b)(5)(B) (2006). See also REITZE, *supra* note 30, at 161.

<sup>37</sup> 42 U.S.C. § 7411(d) (2006); see also REITZE, *supra* note 30, at 161.

<sup>38</sup> See 42 U.S.C. § 7411.

<sup>39</sup> There are 69 source categories. See 40 C.F.R. § 60, Subpart C (2006).

<sup>40</sup> 42 U.S.C. § 7411(a).

<sup>41</sup> See 42 U.S.C. § 7411.

<sup>42</sup> *Id.*

<sup>43</sup> See Standards of Performance for Electric Utility Steam Generating Units for Which Construction Is Commenced After September 18, 1978, Standards of Performance for Industrial-Commercial-Institutional Steam Generating Units, and Standards of Performance for Small Industrial-Commercial-Institutional Steam Generating Units, 70 Fed. Reg. 9706, 9708 (Feb. 28, 2005) (hereinafter Standards of Performance for Steam Generating Units).

what antiquated. In fact, many industry and environmental groups believe that the NSPS system needs to be drastically overhauled or eliminated as it is often duplicative and unnecessary for sources already facing NSR requirements.<sup>44</sup>

Because the NSPS have evolved over time, and existing sources have been continually grandfathered-in, different requirements are imposed on facilities based entirely on when the facility was constructed.<sup>45</sup> For coal-fired electric plants, the NSPS do not apply to units constructed before 1971 (although independent state SIP controls may apply); the standards have the following general limitations for units built after 1971:

Construction Group One: if the unit was constructed between 1971 and 1978, it must have PM controls (an ESP) and emit less than 1.2 lbs/mmBTU (heat input) of SO<sub>2</sub>. There is no NO<sub>x</sub> limit, and the unit can usually meet the SO<sub>2</sub> limit by burning low-sulfur coal.<sup>46</sup>

Construction Group Two: if the unit was constructed between 1978 and 1990, it must have PM controls (an ESP), meet NO<sub>x</sub> limits (based on type of fuel used), and have a 70/90% reduction in SO<sub>2</sub> in addition to the 1.2 lbs/mmBTU requirement (usually requires a scrubber).<sup>47</sup>

Construction Group Three: Units constructed after 1990 are still required to install a scrubber and meet the 1.2 lbs/mmBTU SO<sub>2</sub> standard; however, the facility also must obtain adequate emission allowances from the market.<sup>48</sup>

In addition, electric utility boilers constructed or modified after July 9, 1997, must generally install SNCR or SCR technology (for NO<sub>x</sub> control).<sup>49</sup>

---

<sup>44</sup> See REITZE, *supra* note 30, at 163 (“NSPS regulations generally have not been updated in recent years while programs under the PSD and nonattainment provisions have become more important to industrial sources seeking to construct or modify facilities.”). However, EPA has proposed recent revisions to various NSPS regulations. See Standards of Performance for Steam Generating Units, 70 Fed. Reg. 9706 (Feb. 28, 2005).

<sup>45</sup> See 40 C.F.R. §§ 60.42a–44a (2006).

<sup>46</sup> See *id.*; REITZE, *supra* note 30, at 166.

<sup>47</sup> 40 C.F.R. §§ 60.42a–44a.

<sup>48</sup> *Id.*

<sup>49</sup> “EPA’s emissions ‘limits are based on the use of selective catalytic and selective noncatalytic reduction technologies, which the Agency predicted would cost about \$1,500 per ton of nitrogen oxides removed.’” REITZE, *supra* note 30, at 166 (citing Alec Zaccaroli, *Final Rule Sets Fuel Neutral NO<sub>x</sub> Standard for New or Rebuilt Utility, Industrial Boilers*, Daily Env’t Rep. (BNA), at AA-1 (Sept. 8, 1998)).

*B. New Source Review*

Congress adopted the NSR program in 1977. NSR requires sources to install the most currently available control technology if the source is undergoing construction or modification in a nonattainment area<sup>50</sup> or if the modifications will affect certain areas which meet the NAAQS (called Prevention of Significant Deterioration ("PSD") areas).<sup>51</sup> Generally speaking, NSR emissions limitations are stricter than those contained in the EPA issued NSPS for major sources.<sup>52</sup> While there are some facilities that are subject to an NSPS and not to NSR, the majority of electricity generating facilities are subject to both NSR and an NSPS.<sup>53</sup> NSR establishes emissions limitations and work-practice procedures based on either the Best Available Control Technology ("BACT") or the Lowest Achievable Emissions Rate ("LAER").<sup>54</sup> BACT is required for modifying sources in attainment areas<sup>55</sup> or unclassifiable<sup>56</sup> areas that are undergoing PSD permitting, and LAER is required in nonattainment areas.<sup>57</sup> BACT and LAER are technology standards, but they are expressed as emissions limitations. LAER is generally more stringent than BACT, and both BACT and LAER must be as stringent as, or more stringent than, the applicable NSPS emissions limitation.<sup>58</sup> In nonattainment areas, in addition to meeting the LAER standard, facilities must also obtain emissions reductions (called offsets) from existing sources.<sup>59</sup> Sources can obtain these offsets from facilities within their area or from sources in other nonattainment areas provided that the other nonattainment area's air quality is at least as poor as their area's air quality.<sup>60</sup>

---

<sup>50</sup> Nonattainment areas are areas that do not meet the NAAQS. 42 U.S.C. §§ 7407(d), 7501(2) (2006).

<sup>51</sup> PSD areas also include areas where there was insufficient information to evaluate whether the NAAQS have been met. *See* 42 U.S.C. §§ 7470–92 (2006).

<sup>52</sup> *See* REITZE, *supra* note 30, at 162 ("NSPS apply to sources that are not major sources and usually are the minimum requirements for the more stringent NSR program that is applicable to major stationary sources").

<sup>53</sup> *See* Standards of Performance for Steam Generating Units, *supra* note 43, at 9709 (Feb. 28, 2005) (pointing out that some steam generating electric facilities are subject to an NSPS and not NSR).

<sup>54</sup> 42 U.S.C. §§ 7479(3), 7501(3).

<sup>55</sup> An area is in attainment if it meets the primary or secondary NAAQS. 42 U.S.C. § 7407(d)(1)(A)(ii).

<sup>56</sup> An area is unclassifiable if its air "cannot be classified on the basis of available information as meeting or not meeting the national primary or secondary ambient air quality standard for the pollutant." 42 U.S.C. § 7407(d)(1)(A)(iii).

<sup>57</sup> 42 U.S.C. §§ 7479(3), 7501(3).

<sup>58</sup> 42 U.S.C. § 7479(3) ("In no event shall application of [BACT] result in emissions of any pollutants which will exceed the emissions allowed by any applicable standard established pursuant to [the NSPS provisions].").

<sup>59</sup> 42 U.S.C. § 7503(c) (2006).

<sup>60</sup> *Id.* For example, a newly modified source in a nonattainment area that would have a fifty ton per year increase after the modification would have to obtain offsets from other facilities to mitigate this increase.



### C. Triggering the NSPS and NSR: The Modification Rules

Determining what triggers an NSPS or NSR under EPA's rules is very complex because there are so many issues currently in litigation.<sup>61</sup> According to EPA's regulations, a source's modification will trigger NSR or an NSPS if: (1) a physical or operational change has occurred at the facility; and (2) this change will cause a "significant net emissions increase."<sup>62</sup> While courts have interpreted "physical change" broadly,<sup>63</sup> EPA's regulations exclude routine maintenance, repair, and replacement from the term, which is the critical and oft-litigated portion of this rule.<sup>64</sup> To determine what is routine, EPA has historically looked to the "nature, extent, purpose, frequency, and cost" of a proposed project.<sup>65</sup> As to determining whether a "significant net emissions increase" will occur, EPA uses an hourly emissions rate test for the NSPS—that is, the facility must show that the physical change will not cause the unit's hourly emissions to increase. Conversely, EPA uses an annual emissions test for NSR.<sup>66</sup>

#### 1. A Physical Change: The Routine Maintenance Exclusion

Although EPA has made multiple rulings on its routine maintenance exclusion, the *Wisconsin Electric Power Co. v. Reilly* ("WEPCO") decision is the only federal appellate court decision to directly deal with EPA's rule.<sup>67</sup> Unfortunately, *WEPCO* is of limited use in determining what *actually* constitutes routine maintenance: Wisconsin Electric Power Company lost on the routine maintenance issue because the facts were weighted heavily

---

<sup>61</sup> Compare, e.g., *United States v. Duke Energy Corp.*, 411 F.3d 539 (4th Cir. 2005), cert. granted, 126 S.Ct. 2019 (U.S. May 15, 2006) (No. 05-848) (invalidating the hourly/yearly distinction in NSR and NSPS) with *United States v. Cinergy Corp.*, 384 F.Supp.2d 1272 (S.D. Ind. 2005) (upholding the hourly/yearly distinction); compare also *United States v. Ohio Edison Co.*, 276 F.Supp.2d 829, 853 n.10 (S.D. Ohio 2003) with *United States v. Duke Energy Corp.*, 278 F.Supp.2d 619, 630 (M.D.N.C. 2003).

<sup>62</sup> See 42 U.S.C. §§ 7411(a)(4), 7479(1)(C) (2006).

<sup>63</sup> See, e.g., *Wis. Elec. Power Co. v. Reilly*, 893 F.2d 901, 905 (7th Cir. 1990) ("[T]he most trivial activities—the replacement of leaky pipes, for example—may trigger the modification provisions if the change results in an increase in the emissions of a facility.").

<sup>64</sup> See 40 C.F.R. § 60.14(e)(1) (2006).

<sup>65</sup> Memorandum from Don R. Clay, Acting Assistant Adm'r for Air and Radiation, EPA, to David A. Kee, Dir. of Air and Radiation Div., Region V, EPA, Applicability of Prevention of Significant Deterioration (PSD) and New Source Performance Standards (NSPS) Requirements to the Wisconsin Electric Power Company (WEPCO) Port Washington Life Extension Project 3 (Sept. 9, 1988), available at [http://www.epa.gov/ttn/nsr/psd1/p4\\_37.html](http://www.epa.gov/ttn/nsr/psd1/p4_37.html) [hereinafter Clay Memorandum]. In a 2002 rulemaking, EPA attempted to broaden the routine maintenance exclusion to exclude replacements constituting less than twenty percent of the value of the process unit, but the D.C. Circuit invalidated the rule. *New York v. EPA*, 443 F.3d 880 (D.C. Cir. 2006) (invalidating Equipment Replacement Provision of the Routine Maintenance, Repair and Replacement Exclusion, 68 Fed. Reg. 61,248 (Oct. 27, 2003) (final rule)).

<sup>66</sup> 40 C.F.R. § 52.21(b)(21)(ii) (2006).

<sup>67</sup> 893 F.2d at 910–13. *WEPCO* is well known primarily because of its decision on the significant increase in emissions issue, not the routine maintenance issue.

against the work being routine.<sup>68</sup> The total cost of the Company's project was \$70.5 million, and the project required four successive nine-month outages.<sup>69</sup> *WEPCO*, however, is important for illustrating the process EPA has historically used in deciding what constitutes routine maintenance.

As the court pointed out, EPA "makes a case-by-case determination by weighing the nature, extent, purpose, frequency, and cost of the work, as well as other relevant factors, to arrive at a common-sense finding."<sup>70</sup> In making its *WEPCO* determination, EPA looked at the nature and extent of the project and found that its magnitude was "more than routine."<sup>71</sup> Regarding frequency, EPA noted that the company's project was unprecedented both at the plant itself and industry-wide.<sup>72</sup> Finally, EPA found that the stated purpose of the work (the plant's "life extension") and the considerable cost of the project (\$70.5 million) indicated that the proposed project was not routine. After evaluating EPA's analysis, the Court of Appeals found that EPA's use of these factors to determine whether or not the maintenance was routine "was not arbitrary or capricious."<sup>73</sup>

## 2. *Measuring a "Net Emissions Increase"*

Again, under EPA's rules, to trigger NSR or an NSPS there must be both a physical, non-routine change, and a projected net emissions increase. As stated earlier, EPA mandates a different measurement test for NSR than for NSPS when determining whether a net emissions increase will occur.<sup>74</sup> For the NSPS, EPA requires an emissions rate test (kg/hr), and for NSR, EPA requires a total annual emissions test (kg/yr).<sup>75</sup> Measuring a potential NSR annual increase is considerably more complicated than measuring an hourly NSPS increase. To measure a potential NSR annual increase, the facility starts with a baseline number constituting "the average rate, in *tons per year*, at which the unit actually emitted" for any two

---

<sup>68</sup> *Id.*; see also *United States v. S. Ind. Gas & Elec. Co.*, 245 F.Supp.2d 994, 1017 (S.D. Ind. 2003) (*WEPCO* was an easy case on routine maintenance—the EPA and the Seventh Circuit quickly disposed of the defendant's arguments that it qualified for routine maintenance).

<sup>69</sup> *WEPCO*, 893 F.2d at 910–12.

<sup>70</sup> *Id.* at 910 (quoting Clay Memorandum, *supra* note 64).

<sup>71</sup> *Id.* at 911.

<sup>72</sup> *Id.*

<sup>73</sup> *Id.* at 913. For a more detailed discussion of the routine maintenance issue, see *United States v. Ohio Edison Co.*, 276 F.Supp.2d 829, 853 n.10, 859 (S.D. Ohio 2003). See also *In re Tennessee Valley Authority*, 9 E.A.D. 357 (Env'tl. App. Bd. Sept. 15, 2000).

<sup>74</sup> This difference was recently held unconstitutional in the Fourth Circuit. However, it is still the rule in all other circuits. *United States v. Duke Energy Corp.*, 411 F.3d 539 (4th Cir. 2005), *cert. granted*, 126 S.Ct. 2019 (U.S. May 15, 2006) (No. 05-848).

<sup>75</sup> 40 C.F.R. § 60.14(b) (2006); 40 C.F.R. § 52.21(a)(2)(iv)(c) (2006). EPA has recently proposed changing the NSR measurement to an hourly test mirroring the NSPS rule. *Prevention of Significant Deterioration, Nonattainment New Source Review, and New Source Performance Standards: Emissions Test for Electric Generating Units*, 70 Fed. Reg. 61,081 (Oct. 20, 2005).

consecutive years<sup>76</sup> of the ten preceding years. In doing so, the facility is allowed to take into account the “unit’s operating hours, production rates, and types of materials processed, stored, or combusted during the selected time period.”<sup>77</sup> The facility then compares this annual baseline amount to the projected actual post-project emissions to see if there will be a “significant net emissions increase.” This is known as the “actual-to-projected-actual test.”<sup>78</sup>

For the NSPS, on the other hand, the facility measures emissions increases based on an hourly rate rather than a projected annual rate, which is much easier to do because it does not, for example, involve estimates of a unit’s increased use after the project.<sup>79</sup> This hourly/yearly distinction is important. If EPA requires an annual rate, an increase in the total hours a unit is projected to operate could trigger a “significant net emissions increase” even without an increase in the hourly emissions rate. However, if EPA uses an hourly rate, only an increase in the hourly emissions can constitute a “significant net emissions increase.” Thus, a project can trigger NSR much more easily than the NSPS, and since NSR is more stringent than the NSPS, NSR requirements demand a greater focus.

*D. Complying with NSR: The Best Available Control Technology (BACT) and the Lowest Achievable Emissions Rate (LAER) Standards*

If an existing facility’s project triggers NSR (i.e., its project is a physical change and causes an annual emissions increase), it must meet the BACT or LAER standard depending on whether it is located in an attainment or nonattainment area, respectively. For simplicity, this Article focuses primarily on the BACT standard and does not conduct a complete analysis of the LAER standard. It is important to keep in mind, though, that the LAER standard is generally more stringent than the BACT standard, and that offsets are required in nonattainment areas.

The CAA requires new or modified sources to construct the facility with “the best available control technology for each [CAA regulated] pollutant . . . emitted from, or which results from, such facility.”<sup>80</sup> The BACT standard does not apply to any listed hazardous pollutants regulated under CAA section 112.<sup>81</sup> The CAA’s definitional section defines BACT as:

---

<sup>76</sup> The previous rule before EPA’s 2002 NSR reform was that the baseline was measured over the immediately preceding two years; however, there were circumstances where EPA might measure other years at their discretion. *See New York v. EPA*, 413 F.3d 3, 10 (D.C. Cir. 2005) (upholding EPA’s new NSR baseline calculation rule, 40 C.F.R. § 52.21(b)(48)(ii)). The period is five years for electric facilities (40 C.F.R. § 52.21(b)(48)(i)).

<sup>77</sup> 40 C.F.R. § 51.166(b)(21)(ii) (2006).

<sup>78</sup> 40 C.F.R. § 52.21(a)(2)(iv)(c).

<sup>79</sup> *See United States v. Duke Energy Corp.*, 278 F.Supp.2d 619, 630 (M.D.N.C. 2003).

<sup>80</sup> 42 U.S.C. § 7475(a)(4) (2006).

<sup>81</sup> Nonetheless, some states, like Wisconsin, use the BACT standard for listed hazardous air pollutants (HAPs) anyway. Wis. Admin. Code § NR 445.02(1m) (2006).

an emissions limitation based on the *maximum degree of [pollutant] reduction . . . which the permitting authority, on a case-by-case basis, taking into account energy, environmental, and economic impacts and other costs, determines is achievable for such facility* through application of production processes and available methods, systems, and techniques, including fuel cleaning, clean fuels, or treatment or innovative fuel combustion techniques for control of each such pollutant.<sup>82</sup>

In lieu of an emissions limitation, regulating authorities can impose equipment, work-practice, and operational standards (or any combination thereof).<sup>83</sup>

Obtaining an NSR permit in a nonattainment area is more complex than in an attainment area. The agency will not issue an NSR permit to a facility in a nonattainment area unless the following five conditions are met: (1) the facility has obtained adequate offsets; (2) the source will comply with LAER; (3) the source's owner is generally in compliance with all emissions limitations or standards at every other source owned in the state; (4) EPA has not questioned the adequacy of the state SIP for the nonattainment area; and (5) the source has conducted an analysis of sites, sizes, production processes, and environmental control techniques and determined that the source's benefits significantly outweigh its environmental and social costs.<sup>84</sup> Unlike the BACT analysis, LAER does not require agency consideration of the energy, environmental, and economic impacts of the technology.<sup>85</sup> Rather, LAER mandates that sources use the *most stringent* of either: the lowest emission limitation located in the SIP for its source category, "unless the owner or operator of the proposed source demonstrates that such limitations are not achievable," or "the most stringent emission limitation which is achieved in practice by such class or category of source."<sup>86</sup>

### *E. The Current Legislative and Regulatory Emissions Trading Schemes*

As part of the 1990 CAA Amendments, Congress instituted the first large-scale emissions trading scheme,<sup>87</sup> which EPA subsequently dubbed the "Acid Rain Program" because curtailing acid rain was its primary purpose.<sup>88</sup> The program, found in CAA Title IV, regulates only SO<sub>2</sub> from

<sup>82</sup> 42 U.S.C. § 7479(3) (2006)(emphasis added). See also 40 C.F.R. § 51.166(b)(12) (2006) (containing the regulatory definition).

<sup>83</sup> 42 U.S.C. § 7479(3); REITZE, *supra* note 30, at 197.

<sup>84</sup> 42 U.S.C. § 7503(a) (2006); REITZE, *supra* note 30, at 203.

<sup>85</sup> Compare 42 U.S.C. § 7501(3) (2006) (defining nonattainment LAER standard) with 42 U.S.C. § 7479(3) (defining BACT standard). See also REITZE, *supra* note 30, at 204.

<sup>86</sup> 42 U.S.C. § 7501(3).

<sup>87</sup> 42 U.S.C. § 7651(a)-(o) (2006).

<sup>88</sup> EPA, Acid Rain Program: Overview, <http://www.epa.gov/airmarkt/arp/overview.html>

fossil-fuel fired power plants<sup>89</sup> and employs what economists call a cap-and-trade program.<sup>90</sup> As the name implies, cap-and-trade mandates a set limit on total emissions per year but allows sources to transfer or purchase emissions allowances.<sup>91</sup> Congress set a cap on the total annual tons of SO<sub>2</sub> emitted per year and delegated emissions allowances in one-ton increments according to an average of facilities' 1985–1987 emissions levels.<sup>92</sup> The allowances are given to the facilities at no cost, are freely alienable, and can be banked (carried over) for future use.<sup>93</sup> The facilities measure their emissions using continuous emissions monitoring systems (“CEMS”)<sup>94</sup> and EPA checks quarterly to ensure that each facility has enough allowances to cover its emissions.<sup>95</sup>

Shortly after taking office, President George W. Bush proposed his Clear Skies Act initiative—a legislative attempt at expanding Title IV to include NO<sub>x</sub> and mercury trading regimes.<sup>96</sup> When this bill stalled in Congress, EPA promulgated a similar regulatory regime, which was divided in its finalized version into two rules: the Clean Air Interstate Rule (“CAIR”) and the Clean Air Mercury Rule (“CAMR”).<sup>97</sup>

(last visited Nov. 24, 2006) (on file with the Harvard Environmental Law Review). Acid rain, which is more aptly termed acid deposition, generally occurs when SO<sub>2</sub> and NO<sub>x</sub> react in the atmosphere. Paul L. Joskow & Richard Schmalensee, *The Political Economy of Market-Based Environmental Policy: The U.S. Acid Rain Program*, 41 J.L. & ECON. 37, 40 (1998).

<sup>89</sup> See 42 U.S.C. § 7651(a)–(o).

<sup>90</sup> See, e.g., Alexander E. Farrell & Lester B. Lave, *Emission Trading and Public Health*, 25 ANN. REV. PUB. HEALTH 119, 124 (2004).

<sup>91</sup> See *id.* at 124–125 (“Typically, the cap is set in mass units (e.g., tons), is lower than historical emissions, and declines over time . . . . The government [then] requires regulated facilities to surrender emission allowances that equal their emissions on a regular basis (sometimes called ‘true up’).”). See also Paul L. Joskow & Richard Schmalensee, *The Political Economy of Market Based Environmental Policy: The U.S. Acid Rain Program*, 41 J. L. & ECON. 37, 41 n.12 (1998) (“[T]hese allowances are like checking account deposits; they exist only as records in the EPA’s computer-based allowance tracking system. This system contains accounts for all affected generating units and for any other parties that want to hold allowances. It can be used to transfer allowances from one account to another.”).

<sup>92</sup> Joskow & Schmalensee, *supra* note 91, at 42. There was a small allowance auction held in the early years of the program. See Farrell & Lave, *supra* note 90 at 129; Renee Rico, *The U.S. Allowance Trading System for Sulfur Dioxide: An Update on Market Experience*, 5 ENVTL. & RESOURCE ECON. 115, 125–26 (1995) (discussing in detail the allowance auction).

<sup>93</sup> 42 U.S.C. § 7651b(b) (2006); DALLAS BURTRAW, RES. FOR THE FUTURE, DISCUSSION PAPER 95-30-REV, COST SAVINGS SANS ALLOWANCE TRADES? EVALUATING THE SO<sub>2</sub> EMISSIONS TRADING PROGRAM TO DATE 6 (1996), available at <http://www.rff.org/Documents/RFF-DP-95-30-REV.pdf>.

<sup>94</sup> See 42 U.S.C. § 7651k(a); 40 C.F.R. § 51.165(a)(xxxii) (2006) (requiring facilities subject to Title IV to install CEMs).

<sup>95</sup> 40 C.F.R. § 75.64 (2006).

<sup>96</sup> H.R. 999, 108th Cong. § 410(a)(2)(D) (2003) (amending 42 U.S.C. § 7651(a)–(o) (2000)).

<sup>97</sup> See Standards of Performance for New and Existing Stationary Sources: Electric Utility Steam Generating Units (CAMR), 70 Fed. Reg. 28,606 (May 18, 2005); Rule to Reduce Interstate Transport of Fine Particulate Matter and Ozone (CAIR), Revisions to Acid Rain

By and large, CAIR and CAMR follow the same regulatory cap-and-trade structure as Title IV, but broaden the program to include NO<sub>x</sub> and mercury allowance trading regimes.<sup>98</sup> CAIR calls for EPA to allocate NO<sub>x</sub> and SO<sub>2</sub> allowances to the states, which then may elect to either participate in the cap-and-trade program, or create their own program to meet their EPA allocated emissions budget.<sup>99</sup> If a state chooses to participate, it will distribute its allowances to the affected sources, which are primarily fossil-fueled power plants.<sup>100</sup> CAIR only applies to eastern states (28 states in all), as these are the states with the greatest ozone and acid rain problems.<sup>101</sup> The CAIR cap levers down in two phases: the first cuts are required in 2009-2010 and the more substantial reductions are required by 2015.<sup>102</sup> CAMR, which replaces the mercury MACT,<sup>103</sup> imposes a similar system for mercury, except that it applies to all states.<sup>104</sup>

Although some have argued for removing the NSR and NSPS requirements under these trading regimes, currently the programs are still in place.<sup>105</sup> Thus, it is important to understand how the two programs relate and interact. For existing facilities participating in trading regimes, the

---

Program, Revisions to the NO<sub>x</sub> SIP Call, 70 Fed. Reg. 25,162 (May 12, 2005).

<sup>98</sup> See EPA, Fact Sheet, Clean Air Interstate Rule Basic Information, <http://www.epa.gov/CAIR/basic.html> (last visited Nov. 24, 2006) (on file with the Harvard Environmental Law Review).

<sup>99</sup> *Id.*

<sup>100</sup> *Id.*

<sup>101</sup> EPA, Clean Air Interstate Rule, <http://www.epa.gov/CAIR/index.html> (last visited Nov. 24, 2006) (on file with the Harvard Environmental Law Review).

<sup>102</sup> EPA, Fact Sheet, *supra* note 98.

<sup>103</sup> A MACT standard, or "maximum achievable control technology" standard, is used only for CAA Section 112 listed hazardous air pollutants, of which there are 188. 42 U.S.C. § 7612(b) (2006). The EPA issued MACT generally sets a strict source-specific emissions standard for all facilities, regardless of age. *Id.* at § 7612(d)(2). If EPA had not exempted power plants from the mercury MACT standards, they would have been subject to what is known as the "MACT floor," requiring them to meet or exceed the average emission limitations achieved by the top 12% of power plants for which EPA has data. According to one analysis, this would have called for a more than 90% reduction in mercury emissions from all affected power plants by 2008, a much greater reduction than under CAMR. See Pamela D. Harvey & C. Mark Smith, *The Mercury's Falling: The Massachusetts Approach to Reducing Mercury in the Environment*, 30 AM. J.L. & MED. 245, 261 (2004) ("The top 12% of comparable sources, the traditional basis for determining MACT, was estimated to yield a 90% overall reduction in mercury emissions."). See also David W. Rugh, *Clearer, But Still Toxic Skies: A Comparison of the Clear Skies Act, Congressional Bills, and the Proposed Rule to Control Mercury Emissions from Coal-Fired Power Plants*, 28 VT. L. REV. 201, 203 (2003) ("Conservative EPA estimates contend that once implemented, the operation of section 112 of the CAA will reduce mercury emissions to 15 tpy by 2008.").

<sup>104</sup> EPA, Clean Air Mercury Rule Basic Information, <http://www.epa.gov/air/mercuryrule/basic.htm> (last visited Nov. 24, 2006) (on file with the Harvard Environmental Law Review).

<sup>105</sup> For example, President Bush's Clear Skies Initiative attempted to remove NSR under its proposed trading regimes. See H.R. 999, 108th Cong. § 483(a) (2003) (amending 42 § 7651-7651o) ("An affected unit shall not be considered a major emitting facility or major stationary source, or a part of a major emitting facility or major stationary source for purposes of compliance with the requirements of parts C and D of Title I").

NSPS and NSR essentially act as a secondary constraint.<sup>106</sup> Regardless of whether a facility has sufficient emission allowances, if it makes an NSR or NSPS triggering modification to its plant, it will be subject to BACT or LAER. This Article investigates the interaction between these two programs in more detail in Part III. But first, this Article examines the environmental control technology available today for electric power generating systems.

## II. ELECTRIC POWER GENERATION AND ITS ENVIRONMENTAL CONTROL TECHNOLOGY: WHAT IS BACT TODAY?

Understanding how a power plant operates and its corresponding control technology options is the first step to understanding the problems with the current trading regimes and the modification rules. As the following Part will illustrate, there are only a few control types for each pollutant, and there are essentially only three NAAQS pollutants of concern. Each pollutant's control technologies are different, though there are some overlapping benefits between them. Because the majority of grandfathered plants burn coal, this Part focuses primarily on environmental controls at coal-burning power plants.

It is unknown when exactly humans discovered that coal would burn,<sup>107</sup> but it is documented that the Chinese used coal as a fuel in about 1000 B.C. and that Welsh Bronze Age cultures used coal for funeral pyres.<sup>108</sup> The Christian Bible references coal, as do the writings of Aristotle, Nicander, and Theophrastus.<sup>109</sup> Today, coal is the most prominent fuel source in the electric industry, especially for older facilities, and modern pollution control techniques have made it possible to burn coal, along with its much cleaner counterpart natural gas, with significantly lower environmental effects.<sup>110</sup>

### A. Steam Generation: How Does It Work?

Steam power plants produce the largest share of electricity in the United States.<sup>111</sup> Because the combustion process occurs outside the engine,

---

<sup>106</sup> This is not true under the CAMR rule because mercury, as a hazardous air pollutant, is not subject to NSR or NSPS regulations.

<sup>107</sup> JAMES G. SPEIGHT, *THE CHEMISTRY AND TECHNOLOGY OF COAL* 363 (2d ed. 1994).

<sup>108</sup> *Id.*

<sup>109</sup> *Id.*

<sup>110</sup> This statement disregards a central problem with coal as a fuel: it produces significantly more CO<sub>2</sub> than other fuel sources.

<sup>111</sup> EPA, OFFICE OF COMPLIANCE, EPA/310-R-97-007, *PROFILE OF THE FOSSIL FUEL ELECTRIC POWER GENERATION INDUSTRY 24* (1997), available at <http://www.epa.gov/compliance/resources/publications/assistance/sectors/notebooks/fossil.html>; see also EDWARD S. RUBIN ET AL., *INTRODUCTION TO ENGINEERING AND THE ENVIRONMENT* 183–84 (2001) (“Steam turbines are the most prevalent method used worldwide for spinning the shaft of an electromechanical generator. By combining two of nature’s most basic elements—fire and

a steam power plant is considered an external combustion engine.<sup>112</sup> Typically, coal, natural gas, or oil combustion heats the system. The schematic below shows the basic steam turbine system, commonly referred to as the Rankine cycle<sup>113</sup>:

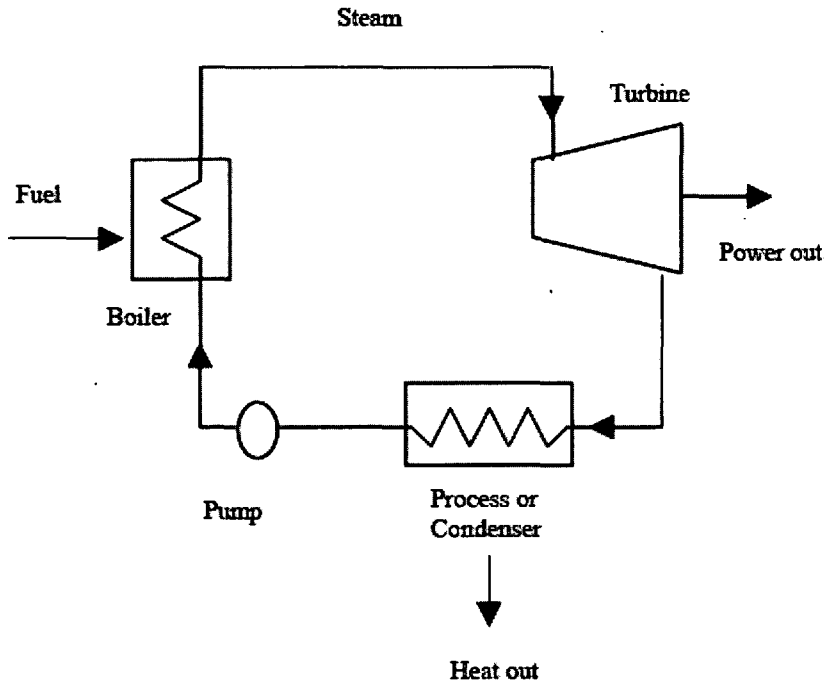

In an older coal-fired plant, the water is first pumped to medium/high pressure and then enters miles of steel tubes inside a huge, building-like boiler, which can range from six to twenty stories tall.<sup>114</sup> Though the design of each boiler differs, generally the boiler consists of various collections of

---

water—high-temperature steam can be generated to produce a hundredfold increase in the electrical output of a turbine generator compared to liquid water alone.”)

<sup>112</sup> See YUNUS A. CENGEL & MICHAEL A. BOLES, *THERMODYNAMICS: AN ENGINEERING APPROACH* 243 (2001).

<sup>113</sup> The cycle is named after a late nineteenth-century Scottish engineer named William Rankine, a pioneer in the thermodynamics field. See RUBIN ET AL., *supra* note 111, at 187. For a more complete description of the Rankine cycle, see CENGEL & BOLES, *supra* note 112, at 521-33. For a discussion of state-of-the-art fossil-fuel power plant design see J. M. Beer, *Combustion Technology Developments in Power Generation in Response to Environmental Challenges*, 26 *PROGRESS IN ENERGY COMBUSTION SCIENCE* 301, 301-27 (2000).

<sup>114</sup> See *United States v. Duke Energy Corp.*, 278 F.Supp.2d 619, 623 (M.D.N.C. 2003). For a more comprehensive discussion see the PROFILE OF THE FOSSIL FUEL ELECTRIC POWER GENERATION INDUSTRY, *supra* note 111. See also BRUCE G. MILLER, *COAL ENERGY SYSTEMS* 204-08 (2005).



tube assemblies at different stages of combustion.<sup>115</sup> After the pump raises the pressure of the water, pulverized coal is combusted in the boiler,<sup>116</sup> often at different stages, and the pressurized water in the various steel tubes is heated to superheated steam at temperatures in excess of 900 degrees Fahrenheit.<sup>117</sup> The superheated steam exits the boiler and enters the turbine where the pressurized steam expands against a series of blades, forcing the turbine shaft to turn.<sup>118</sup> The turbine shaft then turns the generator shaft, transforming mechanical energy into electrical energy.<sup>119</sup> After exiting the turbine, the hot exhaust steam is converted back to water in a condenser (either internal or open air), then pumped through feedwater heaters, beginning the entire process again.<sup>120</sup>

Extremely large quantities of coal (or other fuels) are burned in the boilers to generate electricity. To get an idea of exactly how much coal is burned at power plants, the average household uses about 1000 to 1500 pounds of coal per month. The average power plant will consume millions of tons of coal per year. The products of complete coal combustion are CO<sub>2</sub> and water; however, because complete coal combustion is unachievable, the exhaust gases from the boilers also contain CO, SO<sub>2</sub>, NO<sub>x</sub>, PM, as well as various hazardous air pollutants.<sup>121</sup> Burning natural gas, on the other hand, does not emit significant amounts of SO<sub>2</sub> or hazardous air pollutants.

### B. Retrofitting the "Old Dirties": Technologies and Cost

Understanding the law and technology is vital to understanding the problems with allowance trading and the modification rule in the electric utility context. Coal-fired emissions technology ordinarily comes in four forms classified as phases of the generating process: pre-combustion, combustion, post-combustion, and conversion.<sup>122</sup> For coal-fired steam systems, three principle NAAQS pollutants are the focus of control: SO<sub>2</sub>, NO<sub>x</sub>, and PM.<sup>123</sup>

---

<sup>115</sup> See *Duke Energy Corp.*, 278 F. Supp. 2d at 623. The replacement of some or all of the various tube assemblies is the foundation for many of the current NSR lawsuits.

<sup>116</sup> MILLER, *supra* note 114, at 207. ("Coal is burned in three ways: (1) as large pieces in a fixed bed or on a grate, (2) as smaller or crushed pieces in a fluidized bed, or (3) as very fine particles in suspension.")

<sup>117</sup> *Duke Energy*, 278 F. Supp. 2d at 623.

<sup>118</sup> *Id.*

<sup>119</sup> *Id.*

<sup>120</sup> *Id.*

<sup>121</sup> SPEIGHT, *supra* note 107, at 402.

<sup>122</sup> OHIO DEP'T OF NATURAL RES., DIV. OF GEOLOGICAL SURVEY, GEOFACTS No. 16: COAL AND ELECTRICITY 1 (Mar. 2002), available at <http://www.ohiodnr.com/geosurvey/pdf/geof16.pdf>.

<sup>123</sup> NAT'L RESEARCH COUNCIL, COAL: ENERGY FOR THE FUTURE 138 (1995) [hereinafter NRC REPORT]; MILLER, *supra* note 114, at 284.

*1. Particulate Emission Control: The Electrostatic Precipitator (ESP) and the Fabric Filter*

Particulates, which are commonly referred to as soot or flyash, are the most visible emissions<sup>124</sup> from coal-fired power plants.<sup>125</sup> As such, technological methods of controlling these emissions emerged first.<sup>126</sup> For air pollution purposes, particles of concern are measured in microns.<sup>127</sup> Particles above 10 microns are considered large or coarse, particles less than one micron are considered small or fine,<sup>128</sup> and particles between .7 microns and 7 microns cause lung damage and are known as "lung damaging dust."<sup>129</sup>

The primary technology used today to control particulate emissions, the Electrostatic Precipitator ("ESP"), was actually introduced in 1907 by Doctor F.G. Cottrell.<sup>130</sup> Though the technology was first introduced almost one hundred years ago, its use on large-scale power plants really began about twenty years ago.<sup>131</sup> Electrostatic precipitators principally come in two forms: wet and dry.<sup>132</sup> In the United States today, approximately 75% of the 1100 coal-fired power plants are fitted with dry ESPs.<sup>133</sup> Both ESP types collect emissions in the same three-step fashion. The particles in the flue gas are first charged and then collected on large electrode surfaces as the flue gas passes through the ESP;<sup>134</sup> in a wet ESP, the particles are washed off the collection electrodes with water, and in a dry ESP, the collection electrodes are turned off and mechanically shaken or rapped together.<sup>135</sup> Because washing the electrodes removes more particles, the wet ESP is more efficient and can achieve higher emissions reductions for certain additional pollutants such as mercury.<sup>136</sup> In all, ESPs are amazingly efficient

<sup>124</sup> On cold days, this statement is subject to exception. Thermal pollution (i.e., steam) is often the most visible form of emissions. In fact, under certain circumstances, the "vapor plume" emanating from the cooling tower can produce dense low-lying fog near the plant. RUBIN ET AL., *supra* note 111, at 204.

<sup>125</sup> *Id.*

<sup>126</sup> *Id.*

<sup>127</sup> A micron, or micrometer, is  $1 \times 10^{-6}$  m. KARL B. SCHNELLE & CHARLES A. BROWN, AIR POLLUTION CONTROL TECHNOLOGY HANDBOOK § 19 (2002).

<sup>128</sup> *Id.*

<sup>129</sup> *Id.* This "lung damaging dust" is the most difficult to control because of its small but varying size.

<sup>130</sup> Richard C. Staehle et al., *The Past, Present and Future of Wet Electrostatic Precipitators in Power Plant Applications* 1 (2003), available at <http://www.babcock.com/pgg/tl/pdf/BR-1742.pdf> (on file with the Harvard Environmental Law Review). Dr. Cottrell invented the first WESP to remove a sulfuric acid mist plume from a copper smelter. Ralph Altman et al., *Multi-Pollutant Control With Dry-Wet Hybrid ESP Technology* 2, available at <http://www.netl.doe.gov/technologies/coalpower/ewr/mercury/control-tech/pubs/AQIV-Reynolds.pdf>.

<sup>131</sup> Staehle et al., *supra* note 130, at 1.

<sup>132</sup> *See id.*

<sup>133</sup> Altman et al., *supra* note 130.

<sup>134</sup> Staehle et al., *supra* note 130, at 2.

<sup>135</sup> *Id.*

<sup>136</sup> *Id.*

at controlling particulate emissions. Often ESPs are able to remove 99% or more of PM emissions from the flue gas.<sup>137</sup> To do so, however, ESPs need large plate areas; thus, an ESP housing can easily be as large as a two or three-story building.<sup>138</sup>

The other commonly used particulate emission control technology is the fabric filter, which is often referred to as a “baghouse.”<sup>139</sup> A baghouse is a vacuum like structure containing a set of filter bags<sup>140</sup> and is frequently more efficient at collecting particulate matter than either wet or dry ESPs.<sup>141</sup> Because baghouses can achieve reduction efficiencies above 99.5%, even for small or fine particles, many facilities in industrialized countries have installed them over the last ten years.<sup>142</sup> According to the World Bank, though, ESPs are generally more cost effective for removal efficiencies between 99 and 99.5%: ESPs cost between \$40 and \$60 per kilowatt (kW) of capacity while baghouses cost between \$50 and \$70 per kW.<sup>143</sup> However, baghouses can remove seventy to ninety percent of mercury emissions depending on fuel type, so their use might become more cost-effective if mercury trading is instituted.<sup>144</sup>

## 2. SO<sub>2</sub> Emission Control: FGD and Low Sulfur Coal

Sulfur dioxide is formed when any fuel containing sulfur is burned, and has both local and regional health and environmental effects.<sup>145</sup> When modest reductions of SO<sub>2</sub> are required, many older power plants simply switch fuel types to lower sulfur coal<sup>146</sup> or washed coal.<sup>147</sup> As there are many

<sup>137</sup> RUBIN, *supra* note 111, at 198.

<sup>138</sup> *Id.* at 200.

<sup>139</sup> *Id.*

<sup>140</sup> *Id.*

<sup>141</sup> See the Bagfilter/Baghouse description on the World Bank's website at <http://www.worldbank.org/html/fpd/em/power/EA/mitigatn/aqpcbag.stm> (last visited Nov. 24, 2006) (on file with the Harvard Environmental Law Review).

<sup>142</sup> *Id.*

<sup>143</sup> See also NRC REPORT, *supra* note 123, at 140. (“Current ESPs and fabric filters achieve emission levels of one-third to one-sixth NSPS levels at costs of about \$50 to \$75 per kW and about 2 to 4 mills per kWh in total electricity cost.”).

<sup>144</sup> See WIS. DEP'T OF NATURAL RES., TECHNICAL ADVISORY GROUP ISSUE SUMMARY CONTROL TECHNOLOGY AND OPTIONS 1 (Apr. 29, 2002), available at <http://www.dnr.state.wi.us/org/aw/air/reg/mercury/tag/controltechandop.pdf> (stating that average mercury reductions of 73% are possible for sub-bituminous coal and 89% for bituminous coal).

<sup>145</sup> EPA Office of Air Quality Planning and Standards, SO<sub>2</sub>—HOW SULFUR DIOXIDE AFFECTS THE WAY WE LIVE & BREATHE (NOV. 2000), available at <http://www.epa.gov/air/urbanair/so2/>.

<sup>146</sup> RUBIN ET AL., *supra* note 111, at 200.

<sup>147</sup> There are two types of sulfur in coal: pyritic and organic. Pyritic is an iron compound which is much heavier than the coal itself, and water removes it. Organic sulfur, however, is chemically bound to the coal and cannot be removed prior to combustion. In the washing plants, which are also known as preparation plants or prep plants, approximately 30% to 50% of the pyritic sulfur is removed, resulting in up to a 50% reduction of SO<sub>2</sub> emissions. Ill. Clean Coal Inst., Coal Questions and Answers, <http://www.icci.org/q&a.html> (last visited Nov. 24, 2006) (on file with the Harvard Environmental Law Review).

different types of coal, and corresponding sulfur contents, switching fuel type is often the easiest solution.<sup>148</sup> Lamentably, this is not always a cost-effective or even plausible solution, especially when stringent reductions are required.<sup>149</sup> As such, many power plants—approximately 27%—have installed SO<sub>2</sub> post-combustion control technology known as flue gas desulfurization (“FGD”) systems or scrubbers.<sup>150</sup>

The most common FGD system mixes pulverized limestone with water<sup>151</sup> to create a slurry-like solution which is sprayed into the combustion gases.<sup>152</sup> Limestone is Ca CO<sub>2</sub>, or calcium carbonate, the same chemical gardeners use to neutralize acidic soils and the same chemical used in medicinal antacids.<sup>153</sup> FGD systems can achieve over 95% removal efficiencies using limestone and approximately 98% removal efficiencies using lime in dry scrubbers (CaO).<sup>154</sup> FGD systems also remove large quantities of mercury from the flue gas if the facility is burning bituminous coal.<sup>155</sup> Unfortunately, FGD systems are quite expensive to install and operate for existing plants, costing anywhere from \$220 to \$260 per kW of capacity to retrofit an old plant and about \$50 per kW of capacity in total operational and maintenance costs.<sup>156</sup>

---

<sup>148</sup> Coal’s sulfur content can range from 0.5% to 4%. RUBIN ET AL., *supra* note 111, at 165.

<sup>149</sup> Low sulfur coal (sub-bituminous) is normally found in the western United States and parts of the Appalachian region, while higher sulfur coal (bituminous) is found in the East, Midwest and South. MILLER, *supra* note 114, at 292. Given the high rail transportation costs typically associated with shipping coal over long distances, using low sulfur sub-bituminous coal is often impractical or even impossible in the Midwest. Moreover, a low sulfur content will only bring modest reductions and often sub-bituminous use can increase other problems such as mercury pollution because it has a lower heat value.

<sup>150</sup> See RUBIN ET AL., *supra* note 111, at 202; see also MILLER, *supra* note 114, at 286 (“As of 2000, 192 coal-fired generators were equipped with scrubbers and provided a total of nearly 90,000 MW generating capacity.”); Altman et al., *supra* note 130, at 1.

<sup>151</sup> About 10% of the slurry-like solution is limestone (or lime). World Bank, Wet Flue Gas Desulfurization (FGD), <http://www.worldbank.org/html/fpd/em/power/EA/mitigatn/aqsowet.stm> (last visited Nov. 24, 2006) (on file with the Harvard Environmental Law Review).

<sup>152</sup> See RUBIN ET AL., *supra* note 111, at 200. When the limestone slurry-like solution is added to the combustion gases (often with a small amount of oxygen), SO<sub>2</sub> is removed leaving CO<sub>2</sub> and gypsum, a material used to produce wallboard and other building materials. *Id.* at 200, 205. Most power plants, however, usually just dispose of the gypsum as a solid waste, because natural gypsum is plentiful in the United States and transportation costs usually make it cheaper to simply dispose. *Id.* at 205. Even so, some new wallboard manufacturing plants have been located near several U.S. power plants to utilize this FGD waste. *Id.* See Appendix A for Wet FGD Diagram.

<sup>153</sup> *Id.* at 200.

<sup>154</sup> *Id.* at 201; MILLER, *supra* note 114, at 306. See also World Bank, *supra* note 151. Limestone is preferred over lime because it is much less expensive. See SCHNELLE & BROWN, *supra* note 127, at § 18 tbl. 18.1.

<sup>155</sup> ENERGY INFO. ADMIN., U.S. DEP’T OF ENERGY, ANALYSIS OF ALTERNATIVE MERCURY CONTROL STRATEGIES 6 (2005), available at [http://www.eia.doe.gov/oiaf/servicrpt/mercury/pdf/sroiaf\(2005\)01.pdf](http://www.eia.doe.gov/oiaf/servicrpt/mercury/pdf/sroiaf(2005)01.pdf).

<sup>156</sup> NRC REPORT, *supra* note 123, at 140. See also WORLD BANK, *supra* note 151.

### 3. $\text{NO}_x$ Emission Control: Low- $\text{NO}_x$ Burners, SCR, and SNCR

The term “ $\text{NO}_x$ ” refers to a number of various oxides of nitrogen, but  $\text{NO}$  and  $\text{NO}_2$  are the two principle air pollution concerns.<sup>157</sup>  $\text{NO}$  is a precursor to  $\text{NO}_2$ .<sup>158</sup> Combustion modification, selective catalytic reduction (SCR), and selective non-catalytic reduction (SNCR) are the primary methods of reducing  $\text{NO}_x$  coal-fired emissions.<sup>159</sup> In many circumstances, a hybrid of both combustion and post-combustion methods provides the greatest and most cost-effective reduction.<sup>160</sup>

In combustion modification, the design of the burners or combustion chamber is altered to affect various parameters including flame temperature and time.<sup>161</sup> The term “low- $\text{NO}_x$  burner” is used to describe most reengineered burner designs.<sup>162</sup> Importantly, retrofitting old plants with low- $\text{NO}_x$  burners is sometimes difficult for a number of reasons. For example, the new burners can require a much longer flame length, which can be difficult to fit into the boiler without harming the walls of the combustion chamber.<sup>163</sup> Because each facility is different, unforeseen problems often arise.<sup>164</sup> Nonetheless, if the combustion chamber is large enough, the installation of low- $\text{NO}_x$  burners can reduce emissions from 30% to 60%.<sup>165</sup>

The most expensive and most effective  $\text{NO}_x$  control technology is the SCR process.<sup>166</sup> This technology is widely used in Europe and Japan, and is “becoming the post-combustion technology of choice in the United

---

<sup>157</sup> SCHNELLE & BROWN, *supra* note 127, at § 17 (2002).

<sup>158</sup> *Id.*

<sup>159</sup> RUBIN ET AL., *supra* note 111, at 202; SCHNELLE & BROWN, *supra* note 127.

<sup>160</sup> SCHNELLE & BROWN, *supra* note 127, at § 17.2.

<sup>161</sup> See RUBIN ET AL., *supra* note 111, at 202; see also SCHNELLE & BROWN, *supra* note 127, at § 17.2 (“Some [ $\text{NO}_x$  combustion techniques] reduce the peak flame temperature; some reduce the oxygen concentration in the primary flame zone; and one, reburn, uses the thermodynamic and kinetic balance to promote reconvertng  $\text{NO}_x$  back to nitrogen and oxygen.”); Alaska Dep’t of Env’tl. Conservation v. EPA, 540 U.S. 461, 475 n.6 (2004) (“In Low  $\text{NO}_x$ , changes are made to a generator to improve fuel atomization and modify the combustion space to enhance the mixing of air and fuel.”).

<sup>162</sup> See RUBIN ET AL., *supra* note 111, at 202; see also SCHNELLE & BROWN, *supra* note 127, at § 17.2.1.9:

Low- $\text{NO}_x$  burners are designed to stage either the air or the fuel within the burner tip. . . . With staged-air burners, the primary flame is burned fuel rich and the low oxygen concentration minimizes  $\text{NO}_x$  formation. Additional air is introduced outside of the primary flame where the temperature is lower, thereby keeping the thermodynamic equilibrium  $\text{NO}_x$  concentration low, but hot enough to complete combustion.

See also MILLER, *supra* note 114, at 325.

<sup>163</sup> MILLER, *supra* note 114, at 325; see also NRC REPORT, *supra* note 123, at 140.

<sup>164</sup> See MILLER, *supra* note 114, at 329.

<sup>165</sup> *Id.* at 333.

<sup>166</sup> MILLER, *supra* note 114, at 338; see also Alaska Dep’t of Env’tl. Conservation v. EPA, 540 U.S. 461, 476 (2004) (providing an example in which SCR technology is the most effective).

States.”<sup>167</sup> It is estimated that by 2007, over 200 SCR installations, or approximately 100 GW of capacity, will be utilized to meet the NO<sub>x</sub> standards.<sup>168</sup> The SCR process, which can achieve in excess of 90% reduction, utilizes a catalyst at between 570 to 750 degrees fahrenheit to facilitate a reaction between the NO<sub>x</sub> and the injected ammonia.<sup>169</sup> Because the SCR process needs such high temperatures, the SCR ideally should be located directly after the boiler exhaust.<sup>170</sup> Thus, location of the SCR in retrofit applications is often a problem because there is not enough space between the ESP or other components and the boiler.<sup>171</sup> A less expensive alternative is selective non-catalytic reduction technology, which does not use an expensive catalyst but only achieves reductions between 20% and 50%.<sup>172</sup>

### C. What Is BACT Today?

Since the BACT retrofit standard is site- and cost-specific, it invariably will differ from source to source. Nevertheless, assuming best retrofit conditions at the source, states may require a baghouse for PM, SCR for NO<sub>x</sub>, and limestone injected FGD for SO<sub>2</sub>.<sup>173</sup> The five typical steps in a BACT analysis are to: (1) “Identify available control technologies for the emissions unit, process or activity”; (2) “Eliminate technically infeasible options”; (3) “Rank remaining control options by control effectiveness”; (4) “Evaluate most effective controls and document results”; and (5) select the best remaining technology.<sup>174</sup> When determining what constitutes BACT or LAER, engineers consult the RACT/BACT/LAER clearinghouse, which contains a plethora of state and federal decisions on what constitutes the best available technology.<sup>175</sup> In fact, the CAA requires states to submit their BACT and LAER decisions to the clearinghouse.<sup>176</sup> Unfortunately, the clearinghouse is difficult to use and often contains incomplete data.<sup>177</sup>

---

<sup>167</sup> See MILLER, *supra* note 114, at 338.

<sup>168</sup> *Id.* at 339.

<sup>169</sup> *Id.*

<sup>170</sup> See *id.*

<sup>171</sup> While it is possible to locate the SCR further downstream, this is considerably more expensive and energy-intensive because the exhaust typically must be reheated before entering the SCR. *Id.* at 340.

<sup>172</sup> *Id.* at 342.

<sup>173</sup> See, e.g., Cal. Air Res. Bd., BACT Clearinghouse Database, [http://www.arb.ca.gov/bact/category/boilers\\_coal.htm](http://www.arb.ca.gov/bact/category/boilers_coal.htm) (last visited Nov. 24, 2006) (on file with the Environmental Law Review) (requiring various coal-fired retrofits to install these technologies).

<sup>174</sup> Sanders Engineering & Analytical Services, Inc., BACT Analysis, *at* <http://www.sandersengineering.com/bact.htm> (last visited Nov. 24, 2006) (on file with the Environmental Law Review).

<sup>175</sup> EPA, Technology Transfer Network Clean Air Technology Center RACT/BACT/LAER Clearinghouse, <http://cfpub1.epa.gov/rblc/htm/bl02.cfm> (last visited Nov. 24, 2006) (on file with the Harvard Environmental Law Review).

<sup>176</sup> 42 U.S.C. § 7503(d) (2006).

<sup>177</sup> REITZE, *supra* note 30, at 204.

### III. THE WELFARE LOSSES ASSOCIATED WITH QUANTITY-BASED TRADING, THE MODIFICATION RULE, AND VARYING RATE REGULATION

What exactly is important about this available technology, and how should this available technology affect policy decisions? What is important to understand is that in the electric utility industry both the trading and modification rules essentially aim to control two NAAQS pollutants:  $\text{NO}_x$  and  $\text{SO}_2$ .<sup>178</sup> Although PM is also a concern, over 75% of all generating units have installed ESPs, and curbing  $\text{SO}_2$  and  $\text{NO}_x$  will directly lead to a reduction in PM levels.<sup>179</sup> Therefore, putting PM controls to the side of the policy debate and focusing primarily on  $\text{SO}_2$  and  $\text{NO}_x$  seems appropriate.

There are primarily two technologies for controlling  $\text{SO}_2$ , and three technologies for controlling  $\text{NO}_x$ . For  $\text{SO}_2$ , facilities can either switch to low-sulfur fuel (approximately 30–50% reduction) or install a scrubber (approximately 90–99.9% reduction); for  $\text{NO}_x$ , facilities can either install low- $\text{NO}_x$  burners (approximately 40–65% reduction), Selective Non-Catalytic Reduction systems (approximately 20–50% reduction), or Selective Catalytic Reduction systems (approximately 90% reduction). If the facility is located in an attainment area, the agency can consider technological feasibility and cost when applying NSR (BACT); however, it generally cannot consider these issues if the facility is located in a nonattainment area (LAER).<sup>180</sup> In a LAER determination, then, the facility will almost invariably have to install SCR for  $\text{NO}_x$  and a scrubber for  $\text{SO}_2$ . With a BACT determination, though, the facility may be permitted to install a lesser technology if a scrubber or SCR is cost-prohibitive or not technologically feasible.

#### A. *Quantity-Based Trading is Not Optimal*

More than forty years ago, economists introduced the idea of tradable emissions allowances as a means of controlling air pollution.<sup>181</sup> Under current EPA regulations, emissions trading is used to manage  $\text{SO}_2$ ,  $\text{NO}_x$ , and mercury emissions. Essentially, tradable allowance schemes seek to allocate pollution control technology among the market in a way that is

---

<sup>178</sup> The CAMR is a trading regime aimed at curbing mercury emissions; however, mercury is not a NAAQS pollutant and therefore is not subject to NSR. See 40 C.F.R. §§ 50.4–50.12 (2006) (listing all of the NAAQS pollutants).

<sup>179</sup> See EPA, Greenbook, <http://www.epa.gov/air/oaqps/greenbk/o3co.html#Particulate> Matter (last visited Nov. 24, 2006) (on file with the Harvard Environmental Law Review) (“Particles formed in the atmosphere by condensation or the transformation of emitted gases such as  $\text{SO}_2$  and VOCs are also considered particulate matter.”).

<sup>180</sup> See *supra* Part I.D.

<sup>181</sup> Thomas Crocker, *The Structuring of Atmospheric Control Systems*, in *THE ECONOMICS OF AIR POLLUTION* 61 (H. Wolozin ed., 1966); Barry D. Solomon, *New Directions in Emissions Trading: the Potential Contribution of New Institutional Economics*, 30 *ECOL. ECON.* 371, 371 (1999).

inversely related to cost. As an oft-cited example, see Figure 1, which shows two firms' marginal pollution abatement cost curves (source 1 and 2). Under a command-and-control approach, the regulator sets universal emissions limitations for all sources, regardless of each source's cost of compliance. This can be seen at point B of Figure 1, which assumes that both sources emit the same amount and therefore must abate the same number of tons to meet the standard (7.5). At this point, source 2 has a significantly higher relative marginal cost of reduction than source 1, causing dead-weight loss. Allowing these sources to trade allowances under a cap-and-trade approach alleviates this loss and allows the firms to meet at the equilibrium point A.<sup>182</sup> In this example, source 1 would abate 9 tons and source 2 would abate 6 tons, then source 1 would sell 1.5 ton allowances to source 2 for some price between source 1's marginal cost and source 2's higher marginal cost.

FIGURE 1<sup>183</sup>

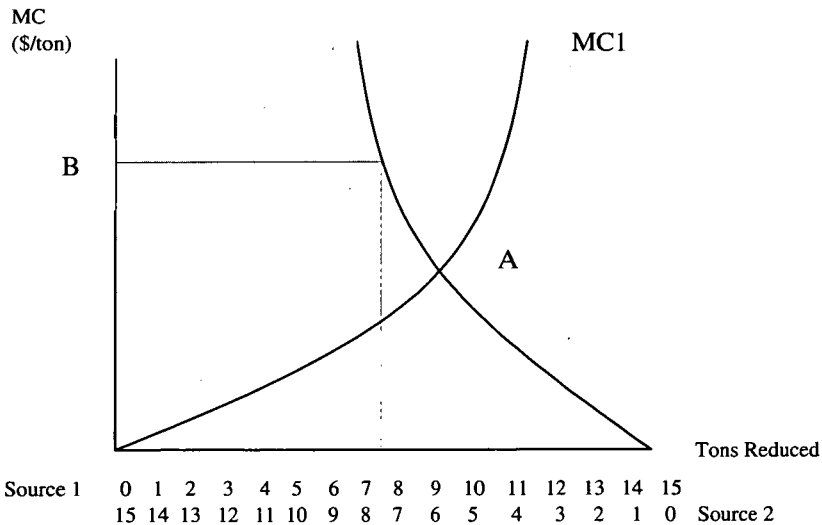

<sup>182</sup> See, e.g., Bruce A. Ackerman & Richard B. Stewart, *Reforming Environmental Law*, 37 STAN. L. REV. 1333, 1334-40 (1985) (arguing that command-and-control is not cost effective due to "variations among plants and industries in the cost of reducing pollution"); Cass R. Sunstein, *Administrative Substance*, 1991 DUKE L.J. 607, 627-31 (pointing out the economic inefficiencies associated with command-and-control). But see Howard Latin, *Ideal Versus Real Regulatory Efficiency: Implementation of Uniform Standards and "Fine-Tuning" Regulatory Reforms*, 37 STAN. L. REV. 1267 (1985) (arguing in favor of command-and-control technology based standards).

<sup>183</sup> See TOM TIETENBERG, ENVIRONMENTAL ECONOMICS AND POLICY 236 (2d ed. 1997).



These tradable allowance schemes are not perfect. As many legal and economic scholars have noted, these schemes do not address the spatial and temporal effects of the pollutant emitted; rather, the schemes assume that all tons (or pounds) emitted are equally damaging.<sup>184</sup> Legal scholars have dubbed this the “currency” problem, in that the currency traded is a ton or quantity emitted, which does not include any price proxy for that ton’s health or environmental impact.<sup>185</sup> In other words, Figure 1 should measure the marginal cost of each firm compared with the harm caused by each reduced ton, not merely the total tons reduced (changing the y-axis measure to harm/ton or harm/pound). Although scholars have suggested many viable solutions to the currency problem,<sup>186</sup> neither Congress nor EPA have heeded their advice. Indeed, all of the current systems follow the traditional tradable allowance model, using the quantity as the sole currency.

### B. NSR and NSPS’s Interaction with the Current Trading Schemes

Understanding how NSR and NSPS interact with the current trading schemes is a bit more complex than understanding the currency problem. For purposes of this examination, this Article will focus only on the modification portion of the NSR and NSPS rules, and will not examine the economic effects of requiring new sources to install BACT or LAER under trading regimes.<sup>187</sup> Although a modification can trigger either NSR or an NSPS, depending on the circumstances,<sup>188</sup> this Article will examine only how NSR interacts with these trading regimes because this should give an adequate understanding of both.

NSR acts as a secondary constraint on the current trading scheme by causing facilities to add pollution controls regardless of cost-effectiveness.

---

<sup>184</sup> See, e.g., Brian H. Potts, *A Clearer Skies Proposal: the Multi-Category Ratio Approach*, 12 N.Y.U. ENVTL. L.J. 286, 296–302 (2004) (discussing proposed solutions to this problem); Jonathan Remy Nash & Richard L. Revesz, *Markets and Geography: Designing Marketable Permit Schemes to Control Local and Regional Pollutants*, 28 ECOLOGY L.Q. 569, 587–88 (2001); James Salzman & J.B. Ruhl, *Currencies and the Commodification of Environmental Law*, 53 STAN. L. REV. 607, 611–13 (2000); Tom Tietenberg, *Tradable Permits for Pollution Control When Emission Location Matters: What Have We Learned*, 5 ENVTL. & RESOURCE ECON. 95, 97 (1995) (“Efficient instruments should be set so as to equate the marginal cost of control with the marginal damage caused by those emissions.”).

<sup>185</sup> See Salzman & Ruhl, *supra* note 184, at 611; Potts, *supra* note 184, at 298 (“The currency problem] is analogous to a tort regime in which the remedy for battery is a fixed amount, regardless of the physical or mental damage to the plaintiff. . . . The industries are being charged by the punch and not for the effects of their punches on our health or our environment.”).

<sup>186</sup> See Potts, *supra* note 184, at 296–309 (outlining the major solutions to the currency problem and proposing an alternate solution).

<sup>187</sup> See Jan Mazurek & Byron Swift, *Cap ‘n’ Trade*, BLUEPRINT MAG., Jan. 22, 2002, available at [http://www.ndol.org/ndol\\_ci.cfm?contentid=250094&kaid=116&subid=155](http://www.ndol.org/ndol_ci.cfm?contentid=250094&kaid=116&subid=155) (“Eliminating NSR provisions for new sources has the potential to actually boost cleaner energy technologies by spreading the economic burden for pollution control more evenly among all electricity generators, rather than just place it on new sources.”).

<sup>188</sup> See *supra* Part I.C.

When an older plant upgrades, it must install BACT or LAER technology regardless of whether it is cost-beneficial to do so. Some argue that this constrains the effectiveness of the trading scheme, while others point out that NSR both ensures that older, grandfathered facilities eventually upgrade and protects certain critical habitats.<sup>189</sup> Typically industry groups point out the former and environmental groups the latter. In reality, both arguments are correct. NSR retards the effectiveness of the trading regimes, but also provides critical environmental benefits. Unfortunately, NSR is not structured to maximize the benefits or minimize the costs.

*C. A Numerical Example of Standard-Market and NSR Welfare Losses*

Consider the three sources in Table 1 below, and assume they are the only sources in the market and that EPA sets the SO<sub>2</sub> cap at 30 tons worth of allowances. Source 1 is an older coal plant that is hard to retrofit with an FGD system, and is located near a midwestern city. Thus, it is expensive to retrofit and its emissions have high health and environmental costs. Source 2 is located closer to a city than Source 1 and therefore has higher health effects, but is an area where its environmental impact is decreased due to wind patterns. Source 2 is also easier to retrofit than Source 1 and is closer to low-sulfur western coal. Finally, assume Source 3 is rurally located further to the west (say mid-Missouri) in an area where its potential environmental and health effects are much lower and where it has easier access to cheap western low-sulfur coal.

TABLE 1

| Source | Tons SO <sub>2</sub><br>Emitted | Health<br>Benefit<br>Per<br>Abated<br>Ton | Environ-<br>mental<br>Benefit<br>Per<br>Abated<br>Ton | Facility<br>Cost Per<br>Abated<br>Ton | Societal<br>Cost Per<br>Abated<br>Ton |
|--------|---------------------------------|---|---|---------------------------------------|---------------------------------------|
| 1      | 20                              | \$20                                      | \$20  | \$80                                  | \$40                                  |
| 2      | 20                              | \$30                                      | \$10  | \$70                                  | \$30                                  |
| 3      | 20                              | \$5                                       | \$5   | \$60                                  | \$50                                  |

Under the current CAA trading regimes, the market would force the sources with the lowest facility cost per abated ton to abate first. Thus,

<sup>189</sup> Gregory Gotwald, *Cap-and-Trade Systems, with or without New Source Review? An Analysis of Proper Statutory Framework for Future Electric Utility Air Pollution Regulation*, 28 VT. L. REV. 423, 449-51 (2004) (arguing that NSR is necessary with trading systems because "the visibility levels in national parks and other Class I areas receive special protection under [NSR].").

the market would force Source 3 to abate all of its pollution and Source 2 to abate 10 tons. This leaves a total of 30 tons emitted at a total abatement cost of \$1,900,<sup>190</sup> but with a total societal cost of \$1,300<sup>191</sup> when counting the environmental and health benefits associated with abatement. While this is the cheapest abatement philosophy for the market, it does not maximize societal welfare because the sources did not take into account the health and environmental benefits associated with their abatement decisions. Had they done so, or had the regulatory scheme been crafted optimally, the market would have forced Source 2 to abate 20 tons and Source 1 to abate 10 tons, for a total societal equilibrium cost of \$1,000.<sup>192</sup> This illustrates the currency problem, but does not take into account NSR.

NSR exacerbates the currency problem and hinders trading in that it forces sources to almost fully abate their pollution regardless of societal or facility cost. In the example above, had the company modified Source 1 and been subjected to NSR, it would have had to abate all or most of the 20 tons at Source 1 to comply with BACT or LAER and total facility costs (\$2,200)<sup>193</sup> and societal costs (\$1,100)<sup>194</sup> would both rise above their optimal levels. However, NSR can also be beneficial by inadvertently mitigating the currency problem. For example, if Source 2 was modified, the facility costs are greater (\$2,000),<sup>195</sup> but the societal costs are in equilibrium. In fact, this effect could be at least partly responsible for why SO<sub>2</sub> hot spots have not been a significant problem.<sup>196</sup> Importantly, NSR modification decisions are not completely cursory. Companies often weigh the potential facility abatement costs when deciding whether to risk triggering NSR. Therefore, under the current NSR system, NSR is more likely to cause societal losses than benefits, since plants often choose to forgo pollution-reducing efficiency upgrades to avoid triggering strict NSR requirements.

---

<sup>190</sup> Abatement costs are the costs to the facility to reduce emissions.  $(\$60 * 20 \text{ tons}) + (\$70 * 10 \text{ tons}) = \$1,900$ .

<sup>191</sup> Societal costs include abatement costs, health benefits, and environmental benefits. Here, societal costs are calculated by subtracting the benefits from the abatement cost.  $(\$50 * 20) + (\$30 * 10) = \$1,300$ .

<sup>192</sup>  $(\$30 * 20) + (\$40 * 10) = \$1,000$ .

<sup>193</sup>  $(\$80 * 20) + (\$60 * 10) = \$2,200$ .

<sup>194</sup>  $(\$40 * 20) + (\$30 * 10) = \$1,100$ .

<sup>195</sup>  $(\$70 * 20) + (\$60 * 10) = \$2,000$ .

<sup>196</sup> In addition, some have argued that SO<sub>2</sub> hot spots did not occur because the cheapest facilities to abate also happened to be the ones with the greatest environmental and health effects (e.g., Midwestern facilities). See, e.g., Tietenberg, *supra* note 184, at 98 ("In the Sulfur Allowance Program the preimplementation modeling showed that the expected reductions from an unrestricted trading system would take place in precisely the areas that would be targeted for greater control by a more complicated [spatial] system.").

*D. Rethinking the Hot Spots Issue: An Unnecessarily  
Narrow Categorization*

In general, NSR interacts with typical trading regimes in three ways: (1) it can increase facility costs; (2) it can increase societal costs; or (3) it can decrease societal costs, thereby mitigating the trading program's currency effects. Regrettably, many scholars do not adequately understand these currency effects, often dubbing them simply as the "hot spots" problem.<sup>197</sup> Hot spots, or locally concentrated areas of pollution, are merely an effect of the currency problem.<sup>198</sup> The currency dilemma itself is much broader. Regardless of whether a specific trade or set of trades creates a hot spot, social welfare is often not maximized. While quantity-based trading regimes do minimize facility costs in abating total nationwide pollution, total welfare benefits are not considered. Thus, although SO<sub>2</sub> hot spots have generally not occurred under Title IV,<sup>199</sup> this does not mean that there have not been significant welfare losses. Moreover, NO<sub>x</sub> trading is much more likely to create hot spots than SO<sub>2</sub> trading because of its temporal and spatial effects and the large number of ozone nonattainment areas to which NO<sub>x</sub> emissions contribute.<sup>200</sup>

*E. The Variable Capital Incentives Problem: Regulatory Restructuring's  
Effect on Firms' Capital Choices*

A final component to consider is that a utility's capital incentives vary depending on how the state regulates electricity. Traditionally, the electric industry was viewed as a natural monopoly<sup>201</sup> and states used rate-

<sup>197</sup> See Lee Ann Fennell, *Revealing Options*, 118 HARV. L. REV. 1399, 1474 (2005) ("[I]n a tradable emissions scheme that allows open-ended trading, environmentally damaging 'hot spots' can develop. . . . [A]llowances can[not] provide reliable information about whether the value a particular polluter places on the ability to pollute exceeds the pollution's actual social cost, as it evolves pursuant to spatial and temporal developments."); David M. Driesen, *Free Lunch or Cheap Fix?: The Emissions Trading Idea and the Climate Change Convention*, 26 B.C. ENVTL. AFF. L. REV. 1, 71 (1998) ("Most trading proponents recognize the need to avoid trading that creates hot spots, concentrations of pollutants with locally significant effects."); Byron Swift, *Allowance Trading and SO<sub>2</sub> Hot Spots—Good News from the Acid Rain Program*, 31 Env't Rep. (BNA) No. 19, at 954 (May 12, 2000).

<sup>198</sup> David B. Spence, *Coal-Fired Power in a Restructured Electricity Market*, 15 DUKE ENVTL. L. & POL'Y F. 187, 217–18.

<sup>199</sup> Shi-Ling Hsu, *Fairness Versus Efficiency in Environmental Law*, 31 ECOLOGY L.Q. 303, 390 (2004).

<sup>200</sup> Ozone is created through a complex reaction between Volatile Organic Compounds (VOC) and NO<sub>x</sub> in the air. EPA, Greenbook Criteria Pollutants, <http://www.epa.gov/air/oagps/greenbk/o3co.html#Ozone> (last visited Nov. 24, 2006) (on file with Harvard Environmental Law Review).

<sup>201</sup> "An industry is a natural monopoly if the production of a particular good or service by a single firm minimizes cost. The typical example is production of a single commodity, where long-run average cost (LRAC) declines for all outputs." W. KIP VISCUSI ET AL.,

of-return regulation to set retail electricity rates.<sup>202</sup> Rate-of-return regulation allows the regulated utility to recoup its capital costs plus some reasonable rate of return.<sup>203</sup> This can create “perverse incentives,” depending on how the regulators set the rate of return.<sup>204</sup> “The key idea is that because allowed profit varies with the rate base (capital), the firm will tend to substitute too much capital for other inputs.”<sup>205</sup>

In restructured electricity markets, on the other hand, the utility is no longer guaranteed a return on its capital expenditures, and thus it may be less likely to make capital investments.<sup>206</sup> In fact, recent empirical evidence suggests that utilities in restructured states tend to install less environmental control technology than those in rate-of-return states.<sup>207</sup> These regulatory differences can cause additional welfare losses. For example, utilities in a restructured state with a low marginal cost of abatement might not install pollution control technology, while utilities in a rate-of-return state might choose to install control technology even though their marginal costs are comparatively higher. Solutions to the currency problem have not taken into account these potential restructuring losses; however, the MEBACT approach would mitigate many of these losses.<sup>208</sup>

#### IV. THREE PROPOSALS FOR MAXIMIZING WELFARE WITHOUT THE MODIFICATION RULE

For the reasons discussed above, EPA and industry groups are dissatisfied with NSR and the NSPS modification rule as applied to fossil-fuel burning power plants. There is a widespread belief that the “modification” system is broken and needs reform. The following sections will examine three recent scholarly proposals for dealing with the grandfathering conundrum through eliminating the modification rule; two focusing on reforming quantity-based trading to mitigate welfare losses and one arguing for a pure command-and-control amortization approach without trading. Under the current leadership, the two trading proposals are unlikely to be implemented, while the pure command-and-control amortization ap-

---

ECONOMICS OF REGULATION AND ANTITRUST 401 (4th ed. 2005).

<sup>202</sup> *Id.* at 430.

<sup>203</sup> *Id.* See also JOSEPH P. TOMAIN & RICHARD D. CUDAHY, ENERGY LAW 130–36 (2004) (discussing the general rate formula).

<sup>204</sup> See VISCUSI ET AL., *supra* note 201, at 433; Harvey Averch & Leland L. Johnson, *Behavior of the Firm Under Regulatory Constraint*, 52 AM. ECON. REV. 1052 (1962).

<sup>205</sup> VISCUSI ET AL., *supra* note 201, at 433.

<sup>206</sup> There are currently nineteen states that have restructured their electricity industries, comprising mainly the Northeastern and Western states. See Seth A. Blumsack, Jay Apt & Lester B. Lave, *Lessons from the Failure of U.S. Electricity Restructuring* 12, available at [http://web.mit.edu/ipc/sloan05/Electricity\\_Restructuring.pdf](http://web.mit.edu/ipc/sloan05/Electricity_Restructuring.pdf).

<sup>207</sup> Meredith Fowlie, *Emissions Trading, Electricity Industry Restructuring, and Investment in Pollution Abatement* 22 (Nov. 28, 2005), available at [http://are.berkeley.edu/~fowlie/job\\_market.pdf](http://are.berkeley.edu/~fowlie/job_market.pdf).

<sup>208</sup> See *infra* Part V.A.

proach is cost prohibitive and doesn't maximize welfare. Moreover, EPA and Congress seem much more poised to replace or remove the NSR and NSPS modification rules than to restructure or remove the current quantity-based trading regimes. Therefore, in Part V, this Article proposes a new replacement program for existing fossil-fuel power plants to work in conjunction with the current quantity-based trading regimes: the MEBACT approach, which maximizes social benefits under the quantity-based trading regimes, while greatly simplifying the entire process.

#### A. *Alternative 1: Solving the Currency Problem Through Trading*

There are currently at least four approaches to dealing with the currency problem through restructuring or modifying the trading regimes, although only two are realistically implementable:<sup>209</sup> the atmospheric dispersion model approach<sup>210</sup> and the multi-category ratio approach.<sup>211</sup> The four approaches focus solely on the welfare losses associated with trading and do not consider nor alleviate the potential losses associated with the variable capital incentives problem.

In theory the best of these four approaches is a pollution offset market, where each trade is subject to ratios defined by the spatial and temporal effects of each traded ton.<sup>212</sup> In other words, the ratios would take into account the time of day and season the pollution was emitted as well as the source location, since each factor has environmental and health consequences.<sup>213</sup> The obvious problem with this approach is that ratios would differ for every traded ton. Moreover, modeling the exact ratio for each trade and administering such a program would be extremely difficult. While theoretically this is the optimal solution, the following proposals are more plausible.

---

<sup>209</sup> Two approaches are currently not feasible for various reasons: the ambient permit system approach and the pollution offset market approach. Scott E. Atkinson & T. H. Tietenberg, *The Empirical Properties of Two Classes of Designs for Transferable Discharge Permit Markets*, 9 J. ENVTL. ECON. & MGMT. 101, 104-06 (1982) (explaining the ambient permit system approach); Alan J. Krupnick et al., *On Marketable Air-Pollution Permits: The Case for a System of Pollution Offsets*, 10 J. ENVTL. ECON. & MGMT. 233, 238-42 (1983) (proposing the pollution offset market approach); Nash & Revesz, *supra* note 184, at 619-23 (pointing out the flaws in both approaches).

<sup>210</sup> Nash & Revesz, *supra* note 184, at 624-25.

<sup>211</sup> Potts, *supra* note 184, at 302-05.

<sup>212</sup> Alan J. Krupnick et al., *supra* note 209, at 238-42. *See also* Fowlie, *supra* note 207, at 3 (finding that "exposure-based permit trading would have moved as much as 300 tons of NO<sub>x</sub> per day out of high damage areas and into low damage areas where the pollution does less damage.")

<sup>213</sup> *See* C.-Y. Cynthia Lin et al., *Trends in Exceedances of the Ozone Air Quality Standard in the Continental United States, 1980-1998*, 35 ATMOSPHERIC ENV'T. 3217, 3227 (2001) (showing the spatial variations in the effect of the two different ozone standards); Mauzerall et al., *NO<sub>x</sub> Emissions from Large Point Sources: Variability in Ozone Production, Resulting Health Damages and Economic Costs*, 39 ATMOSPHERIC ENV'T 2851, 2851 (2005) (showing "that a shift of a unit of NO<sub>x</sub> emissions from one place or time to another could result in large changes in resulting health effects due to O<sub>3</sub> formation and exposure.").

### 1. *The Atmospheric Dispersion Model Approach*

The atmospheric dispersion model approach, which Jonathan Remy Nash and Richard Revesz first proposed in the *Ecology Law Quarterly* in 2001, calls for a typical quantity-based trading market where a proposed trade is rejected if it will lead to a NAAQS violation at any receptor point that is measuring the ambient air.<sup>214</sup> Rejection would be determined on an EPA website through computer modeling where an atmospheric dispersion model predicts the trade's emissions impact.<sup>215</sup> The authors explain the model as follows:

Th[e] determination [of whether or not a trade would be approved] . . . would [be] a fairly straightforward procedure making use of an air quality model. One would simply enter a new emissions vector (incorporating the proposed addition to emissions and deleting the offsetting reductions) and examine through a simulation exercise the projected effects on pollutant concentrations at each of the receptor points. The proposed transaction would be approved so long as there were no violations of standards at any receptor point.<sup>216</sup>

This model would not transform the structure of the quantity-based trading systems. Instead, it simply adds a step to ensure that no ambient standard is violated before allowing a trade. Since allowances are kept in an EPA database anyway, implementation would be fairly straightforward.

While this scheme seems simple and would likely assure compliance with ambient standards, it has a few inherent problems. First, many sources' emissions would always cause a violation, and therefore these sources would be forced to immediately install control technology as they would not be able to obtain allowances through trading. This would greatly reduce the thickness of the trading market, and could cause consumer price shocks.<sup>217</sup> Second, the system could cause races to trade, because prior trades may inhibit another emitter's potential future trades.<sup>218</sup> This causes uncertainty in planning. On the other hand, an otherwise impermissible trade might be made viable by a prior trade.<sup>219</sup> This race to trade would undoubtedly affect the allowance price and could lead to hurried decision-making.<sup>220</sup> Finally, the web-model's cost and feasibility are unproven.<sup>221</sup>

---

<sup>214</sup> Nash & Revesz, *supra* note 184, at 624–25.

<sup>215</sup> *Id.* at 624–26.

<sup>216</sup> *Id.* at 624–25 n.317.

<sup>217</sup> *Id.* at 634–36.

<sup>218</sup> *Id.*

<sup>219</sup> *Id.* at 634.

<sup>220</sup> Potts, *supra* note 184, at 302.

<sup>221</sup> *Id.*

## 2. *The Multi-Category Ratio Approach*

In a 2003 article in the *New York University Environmental Law Journal*, I proposed a different trading scheme—the multi-category ratio approach—which changes the trading system much more significantly in an attempt to interject environmental and health costs into the permit price.<sup>222</sup> The system works as follows: EPA or Congress models future pollution and damage levels for each Air Quality Control Region, placing each region into one of four or five color categories based on its forecasted pollution level and the corresponding health and environmental impacts from emissions in the region.<sup>223</sup> EPA then sets the total number of allowances allocable for each category and distributes them accordingly.<sup>224</sup> Trading intra and inter-category (color allowances) is allowed, where intra-category trades are uninhibited and inter-category trades are based on an exchange rate set by either EPA or Congress.<sup>225</sup> As stated in the article:

The multi-category ratio approach solves many of the problems associated with a single market trading regime . . . [by] adjust[ing] the price of a permit based on the environmental and health effects of pollution [rather than basing] the price solely on the quantity emitted. . . . [Moreover,] much of NSR could be eliminated under the multi-category ratio approach because the price of the permit would be higher in areas where the effects are the greatest.<sup>226</sup>

Although this trading scheme would vastly improve the currency losses associated with quantity-based trading regimes, Congress and EPA do not seem poised to change Title IV's quantity-based trading structure. Given that the failed Clear Skies Act and the CAIR and CAMR rules all use the simple non-ratio trading regimes without an atmospheric dispersion model, it seems unlikely that Congress or EPA will adopt a restructured trading proposal anytime soon. Since Congress and EPA have chosen this uninhibited quantity-based trading approach, and since there is a general consensus that the NSR and NSPS modification rules are not working, it is critical that they be replaced with appropriate provisions.

### *B. Alternative 2: A Pure Command-and-Control Amortization Approach*

Deepa Varadarajan proposed a unique non-trading ideology, in the *Yale Law Journal* in 2003, looking to zoning laws to solve the power-plant

---

<sup>222</sup> *Id.* at 302–05.

<sup>223</sup> *Id.* at 303.

<sup>224</sup> *Id.*

<sup>225</sup> *Id.*

<sup>226</sup> *Id.* at 319.



grandfathering conundrum.<sup>227</sup> In her article she calls for the imposition of amortization provisions in the Clean Air Act mandating BACT or LAER implementation by a fixed date as a means of replacing the NSR and NSPS modification rules.<sup>228</sup> These amortization provisions would “provide nonconforming-use owners with a discrete period of time to continue the nonconforming use, during which the owner can amortize or recoup her investment.”<sup>229</sup> As the Supreme Court of North Carolina has opined, “[i]t is reasoned that this opportunity to continue for a limited time cushions the economic shock of restriction, dulls the edge of popular disapproval, and improves the prospects of judicial approval.”<sup>230</sup> At the expiration of the time period, the nonconforming use would either cease operation or come into compliance.<sup>231</sup>

Ms. Varadarajan points out that amortization provisions, while often controversial, have been fairly common since the 1950s.<sup>232</sup> Moreover, a majority of U.S. federal and state courts have upheld them, “provided that the adopted time periods are ‘reasonable.’”<sup>233</sup> Amortization regulations generally use a range of differing time periods depending on land and structure type.<sup>234</sup> For example, billboards may get “months or years,” whereas more substantial structures may get “fifty or sixty years.”<sup>235</sup>

In the power plant context, EPA could set reasonable amortization provisions based on plant “size, generating capacity, and year of construction,” and state agencies could share responsibility “for addressing the special circumstances of individual plants, for example, by hearing petitions for variances.”<sup>236</sup> What is most important, of course, is setting the chronological baselines, which she argues should run from 1970, the year the plants were originally grandfathered out of the CAA.<sup>237</sup> Given that the

---

<sup>227</sup> See Deepa Varadarajan, *Billboards and Big Utilities: Borrowing Land-Use Concepts to Regulate “Nonconforming” Sources under the Clean Air Act*, 112 YALE L.J. 2553, 2557 (2003) (“[T]he incorporation of amortization provisions into the Clean Air Act could provide a viable solution to the problem posed by old sources.”).

<sup>228</sup> *Id.* at 2577.

<sup>229</sup> *Id.* at 2569.

<sup>230</sup> *State v. Joyner*, 211 S.E.2d 320, 324 (N.C. 1975) (quoting R. M. ANDERSON, AMERICAN LAW OF ZONING, sec 6.65, 446–47 (1968)).

<sup>231</sup> *State v. Joyner*, 211 S.E.2d at 324.

<sup>232</sup> Varadarajan, *supra* note 227, at 2570 (citing 7 PATRICK ROHAN, ZONING AND LAND USE CONTROLS, § 41.04[1], at 41-152) (1978).

<sup>233</sup> *Id.*

<sup>234</sup> *Id.*

<sup>235</sup> *Id.*

<sup>236</sup> *Id.* at 2578.

<sup>237</sup> See *id.* at 2580:

It has been the very promulgation of bifurcated control technology requirements that has extended the natural lives of these old plants, conferring upon them a false competitive advantage and creating within the owner expectations of the original investment that might not have been there originally, at the time a pre-1970 plant was built. This is all the more reason to adopt amortization periods that incorporate the notion that these plants became “nonconforming” in the truest

plants' useful lives typically range from thirty to fifty years, the plants could be brought into compliance within a few years rather than decades.<sup>238</sup>

While Ms. Varadarajan's ideas are well taken and have influenced this Article's MEBACT approach, they present a few inexplicable problems. First, her position essentially calls for an almost immediate upgrade of all grandfathered power plants, which could cost over \$100 billion and increase electricity costs by as much as ten percent.<sup>239</sup> In addition, her command-and-control approach<sup>240</sup> has the added disadvantage of forcing certain older plants to upgrade even when there is little environmental or health rationale for doing so. Like most command-and-control approaches, it also does not minimize overall control costs. Nonetheless, her point is important: the NSR and NSPS modification rule is inadequate and the amortization approach is generally a reasonable solution.

#### V. MAXIMIZING WELFARE WITH QUANTITY-BASED TRADING: THE MEBACT APPROACH

The premise behind the MEBACT approach<sup>241</sup> is simple: it aims to limit the social welfare losses associated with standard market, quantity-based trading by forcing certain pivotal fossil-fuel sources to install BACT or LAER technology over time. It focuses only on fossil-fuel electric sources because they are the greatest pollution sector, their control technology and pollution types are fairly universal, and the spatial and temporal effects of their pollution are more readily ascertainable.<sup>242</sup> Starting with each fossil-fuel plant's next Title V operating permit renewal,<sup>243</sup> and continuing every second renewal thereafter (approximately every ten years), EPA or its state counterpart would force certain facilities to install its "Most Effective" BACT or LAER technology. Because most Title V renewals happen at different times across firms, the process would be time-varying and would thereby ease administrative burden.

The "Most Effective" part of the determination is critical and involves the source only having to install pollution control for the most serious NAAQS pollutant it emits (generally NO<sub>x</sub> or SO<sub>x</sub>), if necessary to ensure

---

(though not technical) sense of the word in 1970, the year the old-new divide was set in place.

<sup>238</sup> *Id.*

<sup>239</sup> See *supra* Part II.C.4.

<sup>240</sup> See Varadarajan, *supra* note 227, at 2587 ("I support the justifications posed by the proponents of command-and-control approaches.")

<sup>241</sup> This could also be termed the Most Effective Lowest Achievable Emissions Rate approach if LAER applies.

<sup>242</sup> Congress could implement the MEBACT approach across all sectors; however, because control technologies and emissions vary across the many sectors, implementation would be more difficult.

<sup>243</sup> The CAA requires all NSR or NSPS regulated sources to obtain an operating permit, which in practice is called a Title V permit. 42 U.S.C. §§ 7661(a)-(f) (2006).

attainment or protect health and the environment. In other words, at the facility's next Title V permit renewal, the agency would force the source to install BACT or LAER pollution control technology for the worst pollutant it emits, or none at all if its emissions do not significantly affect nonattainment, public health, or the environment.<sup>244</sup> Once the source goes through its first MEBACT process, it would no longer be subject to NSR or NSPS emissions limitations for *any* pollutant.

The "Most Effective" part of the test has two parts. First, the agency determines whether the source is significantly contributing to any nonattainment area for any pollutant or ozone (NO<sub>x</sub>), and if so, forces the source to meet BACT or LAER for that pollutant. Second, if the source is not contributing to a nonattainment area, the agency (or set regional guidelines) determines if any of the NAAQS pollutants emitted are contributing to a significant adverse environmental effect such as the formation of acid rain (SO<sub>2</sub>), eutrophication (NO<sub>x</sub>),<sup>245</sup> or visibility problems in a Class I area (e.g., a national park).<sup>246</sup> If the source has an adverse environmental effect, then the agency requires the facility to install BACT or LAER technology for that pollutant. Again, the facility is only required to control a maximum of one pollutant during each MEBACT process, and will not necessarily have to control any pollutants. If two different pollutants meet the above test, the agency determines which BACT or LAER technology would be most effective of the two. Moreover, quantity-based trading is still allowed in its current form so the firm can use or sell its abated pollution allowances.

As an example, this Article proposes adding the following section or something similar to the CAA's PSD provisions:

#### Section 7450

#### Existing Fossil-fuel fired steam electric plants

---

<sup>244</sup> Defining what constitutes a "significant effect" would obviously be a contentious issue; therefore, it should be clearly articulated in the rules. Generally speaking, the term "significant" here is not meant to create a broad exception. Instead, it is meant to exempt out sources that have minimal effects and whose costs in installing control technology greatly outweigh any potential benefits.

<sup>245</sup> See EPA, Health and Environmental Impacts of NO<sub>x</sub>, *available at* <http://www.epa.gov/air/urbanair/nox/hlth.html> (last visited Nov. 24, 2006) (on file with Harvard Environmental Law Review) ("Increased nitrogen loading in water bodies, particularly coastal estuaries, upsets the chemical balance of nutrients used by aquatic plants and animals. Additional nitrogen accelerates 'eutrophication,' which leads to oxygen depletion and reduces fish and shellfish populations. NO<sub>x</sub> emissions in the air are one of the largest sources of nitrogen pollution in the Chesapeake Bay.").

<sup>246</sup> A Class I area is classified under the CAA as an international park, a national wilderness area greater than 5000 acres, a national memorial park greater than 5000 acres, or a national park greater than 6000 acres. 42 U.S.C. § 7472(a) (2006).

(a) Applicability

This section applies to all existing fossil-fuel steam electric plants of more than two hundred and fifty million British thermal units per hour heat input;

(b) Duration that existing regulations are to remain in effect

Until such time as the fossil-fuel steam electric plant becomes subject to section 7450(c), all requirements under this Part shall remain in effect; however, once such plant meets the requirements of section 7450(c), it shall no longer be regulated under any other sections in this Part;

(c) The Most-Effective Best Available Control Technology Process

The Administrator shall ensure that every existing fossil-fuel steam electric plant shall, at its next Subchapter V permit renewal (as provided for in Section 7661(a)) and every second permit renewal thereafter, be subject to the best available control technology for one pollutant, which is not already subject to the best available control technology standard, if:

(1) such pollutant is significantly contributing<sup>247</sup> to any nonattainment area, as classified under Section 7502; or

(2) such pollutant is not significantly contributing to any nonattainment area, but is significantly contributing to adverse environmental effects such as acid rain, eutrophication, or visibility in a Class I area; and

(3) in the determination of the Administrator, control of such pollutant compared solely to other emitted pollutants meeting the requirements of section 7450(c)(1) or (2) above, is the most effective means of ensuring environmental and public health protection;

(d) Promulgation of regulations

In determining whether a fossil-fuel steam electric plant's emissions are subject to Section 7450(C)(2) above, the Administrator may implement regional guidelines, which take into account the spatial and temporal effects of each pollutant, such that certain sources located in such regional areas are automatically subject to Section 7450(c)(2).

In addition to this section, the CAA would have to explicitly exempt these sources from all the unit-specific NSPS emissions limitations and would also have to include a similar provision in the nonattainment sections.<sup>248</sup>

---

<sup>247</sup> Congress should define the term "significantly contributing" in this Part. In the alternative, Congress could remove the word "significantly" because EPA could still exclude *de minimis* contributions. See *State of New York v. EPA*, 443 F.3d 880 (D.C. Cir. 2006) (interpreting "any physical change" to exclude *de minimis* changes in an EPA regulation exempting certain equipment replacements from NSR).

<sup>248</sup> The LAER rule may be a bit different in that Congress may want the source to in-

### A. MEBACT's Benefits

Essentially the MEBACT approach minimizes the welfare losses associated with trading while maximizing the benefits of the secondary command-and-control constraint. The MEBACT process has many unique features that make it a workable solution. First, it does not require all sources to install control technology as a pure amortization approach would, yet it would still quicken attainment. In reality, forcing all sources to install the best available pollution control equipment regardless of their pollution effect is wasteful and will unnecessarily drive up facility costs (and corresponding retail charges). While the MEBACT approach does not always ensure the lowest facility cost across sources as pure trading would, the welfare benefits associated with the rule should greatly outweigh any losses from marginal cost inefficiencies. Indeed, the MEBACT approach would virtually assure attainment in most areas within fifteen years,<sup>249</sup> and should significantly curb many critical adverse environmental and health effects even sooner.<sup>250</sup>

Second, the costs of upgrading the grandfathered plants, which are considerable, would be spread out over fifteen to at most twenty-five years, with the most critical changes happening first.<sup>251</sup> Since most of the capital costs associated with BACT or LAER installations are turned directly over to consumers (especially in regulated electricity markets), spreading out the capital costs over time will ease price shocks on retail consumption.<sup>252</sup> In addition, because trading is still allowed, facilities can make the most of their investment decisions, un-hindered by regulation, and thereby minimize facility costs. While the MEBACT approach invariably will hinder some investment decisions, the forced investments that do occur will mitigate the variable capital incentives problem associated with differing state regulations (i.e., rate-of-return states versus restructuring states).<sup>253</sup> This mitigation would occur because high effect sources would be forced to install pollution controls—taking away their decision-making authority. Along the same lines, because the MEBACT approach provides companies with

---

stall LAER for more than one pollutant if more than one pollutant is contributing to the area's nonattainment. Otherwise, a source could control NO<sub>x</sub> (for ozone) and then over the next ten years increase its emissions of SO<sub>2</sub>, hindering the area's SO<sub>2</sub> attainment assuming the area was not in attainment for SO<sub>2</sub> or ozone.

<sup>249</sup> The approach would virtually assure attainment within fifteen years because most facilities would have to install BACT for their worst two pollutants by this time assuming they go through the MEBACT process at their first Title V renewal (within five years of implementation) and their third renewal (ten years later).

<sup>250</sup> Under the approach many midwestern sources would have to install SO<sub>2</sub> scrubbers at the first permit renewal, thereby helping to curb acid rain in the Northeast.

<sup>251</sup> Twenty-five years would be rare since there are only three principle power-plant pollutants (NO<sub>x</sub>, SO<sub>2</sub>, and PM), over 75% of sources have PM controls (ESPs), and it is unlikely that one source would have to meet BACT for all three pollutants.

<sup>252</sup> For a discussion of the likely cost to upgrade all plants, see *supra* Part VI.B.

<sup>253</sup> See *supra* Part IV.D (discussing the variable capital incentives problem).

rigid and foreseeable regulatory timelines, the companies can easily factor in the MEBACT process when making capital investment decisions under the quantity-based trading regime.

Finally, and most importantly, the MEBACT approach mitigates most of the lost social welfare associated with quantity-based trading by ensuring that BACT or LAER is applied to source emissions with high health and environmental costs. In other words, a facility will no longer be able to make its investment decisions based solely on the lowest cost outcome, but rather will have to factor in the likelihood that MEBACT will apply to a source. Additionally, because the NSR and NSPS modification rule is eliminated, facilities can upgrade or modify their plants without fear of triggering NSR or an NSPS emissions limitation.

### *B. MEBACT's Shortcomings*

As with all proposed solutions, the MEBACT approach is not perfect. Its primary problem is that it does not allow complete inter-firm marginal cost abatement as a pure trading approach would. In other words, a firm with relatively high-cost abatement strategies but similar environmental effects as another firm might still be forced to install pollution controls under MEBACT because relative inter-firm marginal cost is not a factor. Even so, this is not a critical flaw in the MEBACT approach: the agency would consider intra-source abatement costs when determining which pollutant control is the most effective for a source under MEBACT, and the agency still considers abatement costs when applying the BACT standard. In addition, this problem would only arise in much more limited circumstances than under a pure command-and-control approach, and when it arose, the facility would be installing pollution control technology because its emissions are significantly detrimental to public health or the environment. Perhaps most importantly, the MEBACT approach works with the current quantity-based trading schemes, which Congress and EPA seem to have no desire to change.

Another potential problem is determining how to set the emissions allowance cap when MEBACT is implemented. Because MEBACT will require some sources to update within the first five years, Congress or EPA will invariably need to change the total emissions cap for  $\text{NO}_x$  and  $\text{SO}_2$ . If the cap is too high, the price of allowances will drop and sources will have less incentive to make pre-MEBACT or non-MEBACT related changes. If the cap is too low, the price of the permit will rise, forcing additional cost on the utilities and correspondingly higher retail electricity costs. To adequately set the cap, EPA will have to estimate the total likely emissions reduction from MEBACT, which might be difficult. In general, EPA should skew its estimates slightly to favor a higher cap under MEBACT rather than a lower cap to help limit electricity price spikes.

The final problem with the MEBACT approach is that it arguably will increase the burdens on administrative agencies. As with many of the aforementioned approaches, the MEBACT approach will involve additional agency oversight and analysis; however, once the first phase is over, the agency would no longer need to worry about policing NSR and NSPS modifications for these sources. Certainly the largest administrative burden would occur within the first five years. During this time, all facilities would have to undergo their first MEBACT analysis while EPA and state agencies learn to implement the new regulations. However, because source's Title V renewal times will vary, the burden should be spread out over time. Moreover, the MEBACT proposal would only apply to about 600 power plants nationwide, and would not apply to all regulated sources.

## VI. THE "OLD DIRTIES": SURPRISING STATISTICS AND THE COST OF A UNIVERSAL UPGRADE

There are a considerable amount of grandfathered plants without adequate controls, and the cost to *immediately* add the best technological controls to all grandfathered plants (SCR and scrubber) is prohibitively expensive.<sup>254</sup> However, under this Article's MEBACT proposal, these grandfathered facilities would be updated one pollutant at a time—updating only the most critical emissions first—which would spread the capital costs over two to three periods (NO<sub>x</sub>, SO<sub>2</sub>, and potentially PM) and spread out the retail electricity cost increases over time.

### A. Surprising Statistics

According to a recent report to Congress, 57% of all fossil-fuel units (1396 units) operating as of 2000 were built before the CAA was adopted in 1972.<sup>255</sup> When examining the relationship between energy produced and pollution emitted, the older units emitted about twice the levels of SO<sub>2</sub> and about 25% more NO<sub>x</sub>.<sup>256</sup> The report also found that 36% of these older units emitted SO<sub>2</sub> at levels exceeding the NSPS grandfathered standards, and 73% emitted NO<sub>x</sub> above the standards.<sup>257</sup> The "additional emissions," those emissions from the older plants that exceeded the NSPS emissions limitations, accounted for 34% of the SO<sub>2</sub> emitted and 60% of the

---

<sup>254</sup> See *infra* Part VI.B (quantifying the cost of a nationwide upgrade of pollution control equipment).

<sup>255</sup> U.S. GEN. ACCOUNTING OFFICE, REPORT NO. 02-709, AIR POLLUTION EMISSIONS FROM OLDER ELECTRIC-GENERATING UNITS 3 (June 2002), available at <http://www.gao.gov/new.items/d02709.pdf> [hereinafter GAO REPORT]. The data presented in this report include all fossil-fuel facilities with generating capacity greater than 15 MW.

<sup>256</sup> *Id.* The older units emitted about the same amount of CO per MW produced.

<sup>257</sup> *Id.*

NO<sub>x</sub> emitted by all older plants.<sup>258</sup> Of the “additional emissions,” older coal plants produced 99% of the SO<sub>2</sub> and 91% of the NO<sub>x</sub>.<sup>259</sup>

### B. Adding Nationwide NO<sub>x</sub> and SO<sub>2</sub> Control Technology

The cost to upgrade the pollution equipment at all of the currently existing plants is substantial: *assuming the worst case scenario*, it would cost about \$60 billion (2004 dollars) to add the best NO<sub>x</sub> pollution control technology to all currently operating coal and natural gas facilities in the United States,<sup>260</sup> and about \$75 billion (2004 dollars) to add SO<sub>2</sub> pollution control (see Appendix B for calculations).<sup>261</sup> Most, if not all, of these costs would be directly passed on to consumers; however, the consumers who would see the largest increases in their electricity bills are also the ones who are currently paying the least (see Figure 2 below). In the eight states with the highest percentage of grandfathered power plants the average cost of electricity is 6.7 cents per kWh, while the remaining 42 states pay on average 10.42 cents per kWh.<sup>262</sup>

If completely turned over to consumers, the cost to modernize all coal and natural gas plants would translate to approximately a 1 cent per kWh increase on industrial and residential electricity bills (see Appendix C for calculations). At worst, this translates to a 10% increase in consumer electricity costs nationwide,<sup>263</sup> bringing the average cost to around 10.89 cents per kWh and increasing per capita electricity costs approximately \$47 per year (see Appendix D for calculations). While this may seem like a steep increase, under this Article’s MEBACT approach this increase would be gradual as power plants modernize or retire over time.

The following chart compares the price of electricity in the eight states with the most grandfathered power plants to the price of electricity in all other states. It also compares the costs in these eight states with the cost

---

<sup>258</sup> *Id.* (noting that most of the additional emissions were released from units located in the mid-Atlantic, midwestern, and southeastern United States).

<sup>259</sup> *Id.*

<sup>260</sup> This assumes Selective Catalytic Reduction is added to every currently operating coal and natural gas facility. MILLER, *supra* note 114, at 320–21 and World Bank, *supra* note 151.

<sup>261</sup> This assumes a wet FGD is added to every coal-fired power plant and includes total operation and maintenance costs. Cost data is taken from MILLER, *supra* note 114, at 320–21 and World Bank, *supra* note 151.

<sup>262</sup> The eight states with the highest percentage of grandfathered power plants are, in order from highest to lowest: Pennsylvania, Ohio, West Virginia, Tennessee, Kentucky, Alabama, Indiana, and Illinois. The percentages were calculated using the GAO Report and total generation data from the U.S. Energy Information Administration website. Data on cost of electricity in all sectors was taken from the U.S. Energy Information Administration website. ENERGY INFO. ADMIN., U.S. DEP’T OF ENERGY, THE ELECTRIC POWER ANNUAL 2005, 5 tbl. 7.4 (2006), available at <http://www.eia.doe.gov/cneaf/electricity/epa/epat7p4.html>.

<sup>263</sup> According to official energy statistics from the U.S. Government, the average retail price of electricity in 2004 was 7.61 cents per kWh. See ENERGY INFO. ADMIN., *supra* note 262.



of electricity in the three most populated states (California, New York, and Texas).

FIGURE 2: COMPARISON OF THE PRICE OF ELECTRICITY

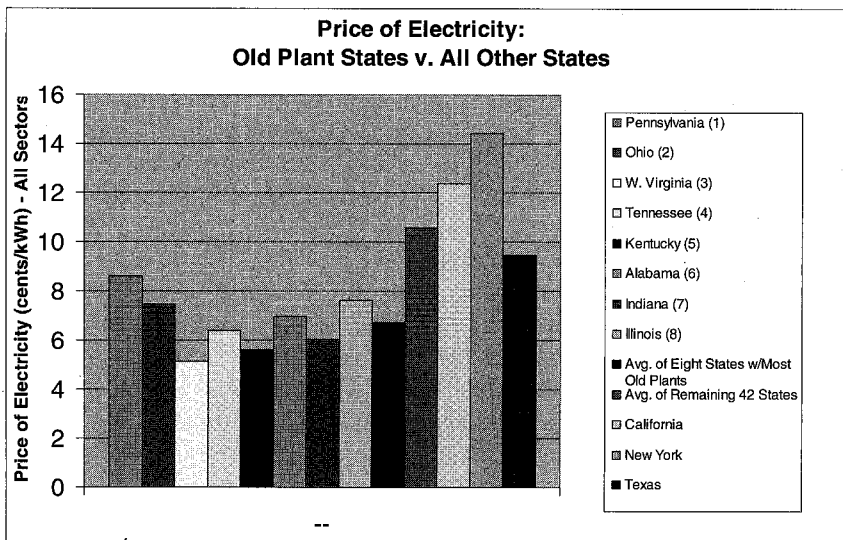

At best, the 1 cent per kWh increase would increase costs primarily in the states with currently lower electricity costs because these states also happen to contain a proportionally larger number of grandfathered power plants (compare the 6.7 cents per kWh with the 10.42 cents per kWh mentioned above). In reality, the price increase will probably fall somewhere in between, at around a 5% average cost increase over time, eventually costing consumers between \$2 and \$4 per person per month for dramatically cleaner air. This seems like a relatively small price to pay, especially when considering the considerable monetary health benefits.

According to a recent Congressional report, assuming all older power plants were brought up to the current NSR pollution control standards by 2020, the fiscal health benefits would be somewhere between \$16 billion and \$66 billion annually.<sup>264</sup> This translates to between \$4.50 and \$19 per person per month in health savings. In other words, when considering the potential per person monthly cost increase for electricity (\$2 to \$4) with the potential monthly per person health benefit (\$4.50 to \$19), the answer

<sup>264</sup> See *Cost and Benefits of Clear Skies: EPA's Analysis of Multi-Pollutant Clean Air Bills* \*9 (Cong. Research Serv., CRS Issue Brief for Congress Order Code RL33165, Nov. 23, 2005), available at <http://www.4cleanair.org/RL33165.pdf> (estimating the benefits of Representative Carper's and Jeffords' Bills to have benefits of \$19 billion and \$66 billion annually by 2020).

seems simple. However, this does not mean we should modernize all plants at once, as this would pose political and economic problems and interfere with reliable electricity distribution. Although the public would benefit financially from such a quick modernization program, strong industry lobbyists would surely trump the public's interest, as the public is difficult to unify, especially behind what essentially is an environmental tax on electricity. Moreover, a ten percent increase in electricity costs over a short time period would significantly affect the economy and mobilizing a work force of engineers to install the equipment takes time.<sup>265</sup> The approach advocated herein, however, will slow this transition and more equitably distribute the costs by stair-stepping the plant installations based primarily on the environmental and public health necessity of each installation.

### CONCLUSION

This Article has examined in detail the primary problems associated with the current grandfathering and trading regimes, and proposed the most viable short-term solution: the MEBACT approach. While there are many theoretical and potentially implementable solutions for modifying the trading regimes to account for the currency problem and the accompanying NSR and NSPS welfare losses, Congress and EPA have repeatedly ignored these proposals. However, virtually all policymakers agree that the NSR and NSPS modification rules need replacing. Whether or not this Article's proposal is adopted, Congress must address the welfare losses associated with trading grandfathered air: maximizing financial efficiency, environmental integrity, and social well-being.

When Congress passed the CAA in 1970, it created the NSPS modification rule, and when this rule did not adequately protect air quality, Congress passed the NSR provisions in 1977. It is now thirty years later and over half of our power plants are still grandfathered out of the CAA's technological requirements. It is time for Congress to act. While it is politically impossible for Congress to force all the grandfathered plants to immediately update their pollution control equipment, it could easily adopt this Article's proposal, which forces the most critical plant upgrades first, and spreads the rest out over time. In so doing, this proposal would virtually assure universal attainment within the next fifteen years, significantly curb acidification and eutrophication, and substantially enhance visibility in the nation's most pristine areas. It would achieve these goals without significant retail price shocks or welfare losses. In short, the MEBACT approach is the superior NSR and NSPS modification rule replacement.

---

<sup>265</sup> See generally EPA, TECHNICAL SUPPORT DOCUMENT FOR THE FINAL CLEAN AIR INTERSTATE RULE, BOILERMAKER LABOR ANALYSIS AND INSTALLATION TIMING (MARCH 2005), available at <http://www.epa.gov/interstateairquality/pdfs/finaltech05.pdf>.

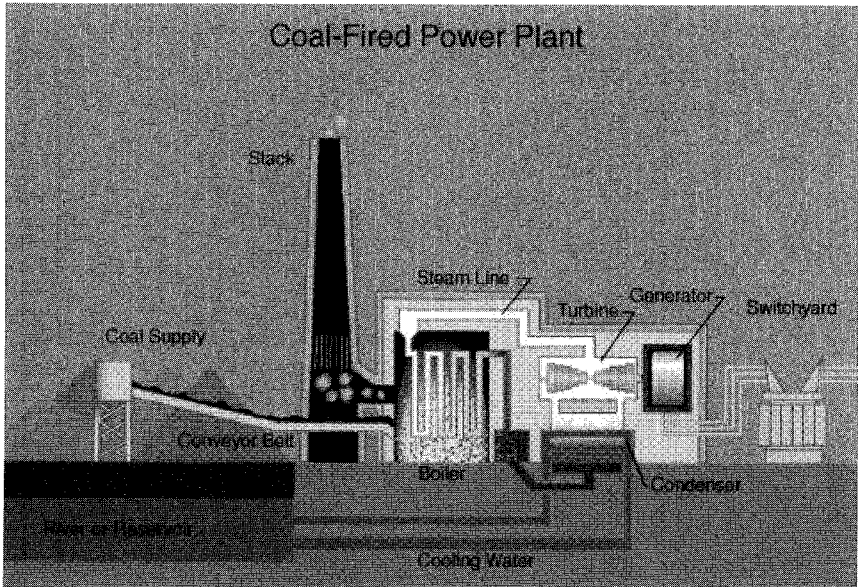
APPENDIX A<sup>266</sup>

---

<sup>266</sup> This is a typical coal-fired power plant without many environmental controls. This diagram was taken from the Tennessee Valley Authority's website at <http://www.tva.gov/power/coalart.htm> (last visited Nov. 24, 2006) (on file with the Harvard Environmental Law Review).

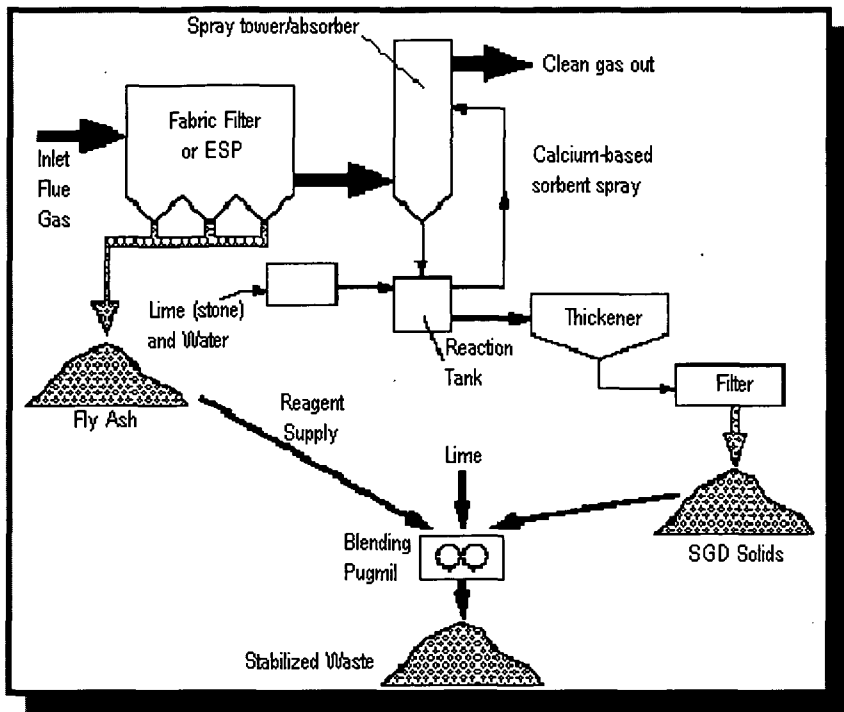
CONVENTIONAL LIMESTONE/LIME WET FLUE-GAS DESULFURIZATION<sup>267</sup>

<sup>267</sup> Chart taken from the World Bank's website at <http://www.worldbank.org/html/fpd/em/power/EA/mitigatn/aqsowet.stm> (last visited Nov. 24, 2006) (on file with the Harvard Environmental Law Review).

APPENDIX B: POLLUTION CONTROL COSTS FOR SO<sub>2</sub> AND NO<sub>x</sub>

The following analysis provides cost estimation for retrofitting all coal-fired power units with a Flue-Gas Desulfurization unit. It includes only coal plants because natural gas plants do not produce significant quantities of SO<sub>2</sub>.

|  |
|--|
| SO <sub>2</sub>  |
| Total U.S. Generating Capacity in 2004 (Coal)  |
| 335,892 MW <sup>268</sup>  |
| Approximate Generating Capacity w/Scrubbers  |
| 90,000 MW <sup>269</sup>   |
| Approximate Cost per kW Capacity to Retrofit   |
| \$180 per kW to \$348 per kW, avg. \$264 per kW <sup>270</sup>   |
| Total Cost Assuming Average Cost For All (including O&M):  |
| $(335,243 \text{ MW} - 90,000 \text{ MW}) * (1000 \text{ kW/MW}) * (\$264 + \$50 \text{ (for O\&M)}) = \$75 \text{ billion}$ |

<sup>268</sup> ENERGY INFO. ADMIN., U.S. DEP'T OF ENERGY, OFFICIAL ENERGY STATISTICS FROM THE U.S. GOVERNMENT (Oct. 4, 2006), available at <http://www.eia.doe.gov/cneaf/electricity/epa/epat2p2.html>.

<sup>269</sup> MILLER, *supra* note 114, at 286.

<sup>270</sup> MILLER, *supra* note 114, at 320–21.

The following analysis provides cost estimation for retrofitting all coal-fired and natural gas units with Selective Catalytic Reduction units.

|   |
|---|
| NO <sub>x</sub>   |
| Total U.S. Generating Capacity (Coal and Nat. Gas)  |
| 591,870 MW <sup>271</sup>   |
| Approximate Generating Capacity w/SCR   |
| 100,000 MW (by 2007) <sup>272</sup>   |
| Approximate Cost per kW of Capacity to Retrofit   |
| \$80 to \$160 per kW capacity, avg. \$120 per kW <sup>273</sup>   |
| Total Cost Assuming Average Cost for All  |
| $(591,870 \text{ MW} - 100,000 \text{ MW}) * (1000\text{kW/MW}) * \$120 =$<br>\$60 billion <sup>274</sup> |

<sup>271</sup> ENERGY INFO. ADMIN., *supra* note 268.

<sup>272</sup> See MILLER, *supra* note 114, at 339 (stating that SCR units have been installed on about 26 GW in the U.S., but that by 2007 "more than 200 SCR installations with overall capacity greater than 100 GW are anticipated to be in place to meet NO<sub>x</sub> targets mandated by the NO<sub>x</sub> SIP-Call."). This analysis uses 100 GW because the NO<sub>x</sub> SIP-Call is not related to the NSR rule change; in other words, the installation of these SCRs will continue regardless of whether EPA changes the rule.

<sup>273</sup> MILLER, *supra* note 114, at 32.

<sup>274</sup> This does not include operating and maintenance costs, which can vary from \$1,500 to \$5,800/MM Btu. MILLER, *supra* note 114, at 346.

APPENDIX C: COST PER KWH OF TOTAL SO<sub>2</sub> AND NO<sub>x</sub> CONTROL

The following analyzes the cost per kWh increase associated with total SO<sub>2</sub> and NO<sub>x</sub> pollution control and the likely percentage increase in the retail cost of electricity. This cost increase does not include potential operation and maintenance costs for NO<sub>x</sub> control.

|  |
|--|
| Cost Per kWh of Total SO <sub>2</sub> and NO <sub>x</sub> Pollution Control                            |
| Total Annualized Cost (assuming a 6% discount rate)  |
| $U = P(r / (1 - (1+r)^{-n})) = (\$60E9 + \$75E9)(.06 / (1 - (1.06)^{-15})) =$<br>\$12 billion per year |
| Total Retail Electricity Sales (2004)  |
| 1,293,586,727 MWh <sup>275</sup>   |
| Cost per kWh Increase  |
| \$12 billion/yr * (1yr/1,293,586,727 MWh) * (MWh/1000kWh) =<br>1 cent per kWh increase                 |
| Total Operating Revenues   |
| \$240 billion per year   |
| Percentage Increase in Retail Cost of Electricity  |
| \$12 billion per year / \$240 billion per year = 5% increase <sup>276</sup>                            |

<sup>275</sup> ENERGY INFO. ADMIN., *supra* note 262.

<sup>276</sup> This conclusion comports with the following study, Frank Ackerman et al., *Grandfathering and Coal Plant Emissions: The Cost of Cleaning up the Clean Air Act*, 27 ENERGY POLICY 929 (1999) (finding a 4.3% increase).

APPENDIX D: AVERAGE PER CAPITA COST INCREASE IF ALL PLANTS  
WERE MODERNIZED

The following analysis first finds the average per capita electricity usage, and then uses this number to calculate what various price increases would cost per month and per year.

|  |
|--|
| Average Per Capita Cost Increase (Month/Year)  |
| Total U.S. Residential Consumption   |
| 1,293,586,727 MWh <sup>277</sup>   |
| Total U.S. Population  |
| 293,700,000 people <sup>278</sup>  |
| Average Monthly Electricity Use Per Person   |
| $1,293,586,727 \text{ MWh/yr} * (1\text{yr} / 12 \text{ months}) * (\text{U.S.}/293,700,000 \text{ people}) * (1000\text{kWh}/\text{MWh}) = 367 \text{ kWh per month}$ |
| Avg. Per Capita Current Cost Per Month (at 9.89 cents per kWh) = \$36  |
| Avg. Per Capita Cost Per Month With 10% Increase = \$40  |
| Avg. Per Capita Cost Per Month With 5% Increase = \$38   |
| Avg. Per Capita Price Increase With 10% Increase = \$47 per yr.  |
| Avg. Per Capita Price Increase With 5% Increase = \$25 per yr.   |

<sup>277</sup> ENERGY INFO. ADMIN., *supra* note 262.

<sup>278</sup> *Id.*